



Instruction

Z-Wave Node Type Overview and Network Installation Guide

Document No.:	INS10244
Version:	4
Description:	This document describes how to setup a network with regard to inclusion of nodes in the network, operation and exclusion of nodes from the network.
Written By:	ABR;JFR;SML
Date:	2007-03-20
Reviewed By:	JFR;LLP;NTJ;RBO;SML
Restrictions:	None

Approved by:

Date	CET	Initials	Name	Justification
2007-03-20	10:27:29	NTJ	Niels Thybo Johansen	

This document is the property of Zensys A/S. The data contained herein, in whole or in part, may not be duplicated, used or disclosed outside the recipient for any purpose other than to conduct technical evaluation. This restriction does not limit the recipient's right to use information contained in the data if it is obtained from another source without restriction.

REVISION RECORD

Doc. Rev	Date	By	Pages affected	Brief description of changes
1	20050118	SML JFR	ALL	Revised document. Added SUC and SIS. Primary Controller does not use Node ID 0xEF anymore.
2	20060105	MVO	All	New 1 st page/header/footer contents. New Doc No
3	20060426	JFR	All	Fixed page number problem
4	20061212	ABR	All	Fixed various small typos Added clarifying comments Added silent ack description to section on routing Added new sections on Zensor Net basics and Zensor Net features
4	20061221	ABR JFR	All	Updated doc after review – minor typos and clarifications

Table of Contents

1	ABBREVIATIONS.....	1
2	INTRODUCTION.....	2
2.1	Purpose.....	2
2.2	Backward compatibility.....	2
2.3	Audience and prerequisites.....	2
3	Z-WAVE BASICS.....	3
3.1	Network Nodes.....	3
3.1.1	Controller Nodes.....	3
3.1.1.1	Portable Controller.....	3
3.1.1.2	Installation Controller.....	3
3.1.1.3	Static Controller.....	4
3.1.1.4	Bridge Controller.....	4
3.1.2	Slave Nodes.....	4
3.1.2.1	Slave.....	5
3.1.2.2	Routing Slave.....	5
3.1.2.3	Enhanced Slave.....	5
3.1.2.4	Zensor Net Routing Slave.....	5
3.2	Home ID.....	6
3.3	Node ID.....	6
3.4	Routing.....	8
3.5	Initiators.....	9
3.5.1	Slave Initiators.....	9
3.5.2	Controller Initiators.....	10
3.6	Node Information Frame.....	10
4	Z-WAVE NETWORK FEATURES.....	11
4.1	Include/exclude Process.....	11
4.1.1	Include Nodes.....	11
4.1.1.1	Include slaves.....	11
4.1.1.2	Include controllers.....	11
4.1.2	Exclude Nodes.....	11
4.2	Association of nodes.....	12
4.2.1	Associating a Slave with a Controller.....	12
4.2.2	Associating a (Routing) Slave with a Routing Slave.....	12
4.2.3	Associating a Static Controller with a Routing Slave.....	12
5	ZENSOR NET BASICS.....	13
5.1	The Zensor Net node.....	13
5.2	The Beam.....	13
6	ZENSOR NET FEATURES.....	16
6.1	Applications.....	16
6.1.1	Doorbell.....	16
6.1.2	Smoke alarm.....	16
6.2	Binding.....	18
6.3	Flooding.....	18
7	BASIC INSTALLATION EXAMPLE.....	20
7.1	Initial Setup.....	20
7.2	Associating Nodes.....	20
7.3	Adding Slave Nodes.....	21
7.4	Adding Controllers.....	22
7.5	Removing Slaves.....	23

7.6 Removing Secondary Controllers.....	23
7.7 Recover from Controller Node Error.....	23
8 STATIC CONTROLLER AND ROUTING SLAVE EXAMPLE	25
8.1 Including Routing Slaves.....	25
8.2 Including Static Controllers.....	27
9 STATIC UPDATE CONTROLLER (SUC) EXAMPLE	29
9.1 Including a SUC to the network.....	29
10 SUC ID SERVER (SIS) EXAMPLE.....	30
10.1 Including a SIS to the network.....	30
10.2 Adding inclusion controllers to the network.....	31
11 REFERENCES	32

Table of Figures

Figure 1. Assigning Home ID and Node ID	6
Figure 2. Unique Home ID for two adjacent homes	7
Figure 3. Routed frame flow	8
Figure 4. Routed frame flow w. silent ack.....	9
Figure 5. Reception timing when sending beams	13
Figure 6. Structure of the beam.....	14
Figure 7. Battery-to-battery communication; direct reach and routed	15
Figure 8. A flooded Zensor Net	17
Figure 9. Including a Slave node.....	20
Figure 10. Associating a Slave Node with a Controller.....	20
Figure 11. Including Slave node 2.....	21
Figure 12. Associating Slave Node 2 with the Controller.....	21
Figure 13. Including a second Controller.....	22
Figure 14. Including and associating additional Slave nodes.....	23
Figure 15. Including a Routing Slave.....	25
Figure 16. Associating a "Simple" Slave with a Routing Slave.....	26
Figure 17. Controller with three associated Routing Slaves.....	27
Figure 18. Including a Static Controller.....	27
Figure 19. Associating a Static Controller with a Routing Slave.....	28
Figure 20. Including a SUC to the network.....	29
Figure 21. Including a SIS to the network.....	30
Figure 22. After SIS is included to the network.....	30
Figure 23. Including an Inclusion Controller to the network.....	31

1 ABBREVIATIONS

Abbreviation	Explanation
ACK	Acknowledge
FLiRS	Frequently Listening Routing Slave
GUI	Graphical User Interface
RTC	Real Time Clock
SIS	SUC ID Server
SUC	Static Update Controller

2 INTRODUCTION

2.1 Purpose

The purpose of this document is to provide guidelines for installation, maintenance and operation of a Z-Wave network consisting of controller and slave nodes. Refer to [1] regarding how the functionality is implemented in the described devices.

2.2 Backward compatibility

The latest Developer's Kits contain new features to improve installation flexibility and network topology distribution of a Z-Wave network. Therefore it is important to understand these features in detail to ensure backward compatibility with Z-Wave enabled products built on older Developer's Kit releases.

From Developer's Kit v3.3x the Static Update Controller (SUC) was introduced to allow slave and controller nodes to request network topology updates.

From Developer's Kit v3.4x the SUC can in addition also function as a node ID server (NIS) to allow other controllers to include/exclude nodes to/from the network. Furthermore the unique node ID 0xEF for primary controllers was discontinued.

From Developer's Kit v4.2x the silent acknowledge mechanism was introduced to reduce routing latency. Refer to section 3.4 for details.

2.3 Audience and prerequisites

The audience is considered to be OEM's implementing the Z-Wave technology into their products.

3 Z-WAVE BASICS

This chapter describes the basic building blocks of the Z-Wave technology.

3.1 Network Nodes

The Z-Wave network consists of two different types of network nodes; controllers and slaves. The controller nodes are able to calculate routes (and alternative routes). The second node type is the slave node, which generally acts as input and output units. Both types exist in different versions as described below. The Z-Wave protocol supports networks of up to 232 nodes, which can be freely shared between controller and slave nodes.

3.1.1 Controller Nodes

A controller in the Z-Wave terminology is defined as a unit that has the ability to host a routing table of the entire network and calculate routes on the basis thereof. Moreover, the controller has the ability to pass on routes to slave units, in order to enable them to transmit routed signals.

Z-Wave networks are established around a controller. The controller used to include the first node is by default configured to act as Primary Controller with the capability to include/exclude nodes. The Primary Controller is used to include all subsequent nodes in the network.

Being primary is just a role. Any controller can be primary but only one controller can be primary at a time. The primary controller manages the allocation of node IDs and gathers information about which nodes can reach each other via direct RF links. More Portable Controllers as well as Static Controllers can be added as needed as the network grows and are denominated as secondary controllers. The secondary controllers can get copies of the network information gathered by the primary controller.

A Static Controller can be enabled to become a Static Update Controller (SUC), which adds advanced self-organization functionalities to the network. A SUC can furthermore be enabled to become a SUC Id Server (SIS), which adds more flexibility to the installation process. At the same time, the SUC improves the self-healing properties of the network, as the SUC introduces a redundant representation of the network topology. Thus, a lost or crashed controller may have its topology awareness restored from the information stored in the SUC. The SIS is by default a Primary Controller because it can to include/exclude nodes. Furthermore it enables other controllers to include/exclude nodes on behalf of the SIS.

The controller exists in a number of fundamentally different versions which are described in the following sections.

3.1.1.1 Portable Controller

The Portable Controller has the ability to discover its own position in the network, when it needs to communicate with other nodes. An example of a device using this type could be a remote control unit, e.g. for controlling light or HVAC systems. Because the Portable Controller can be carried around in the network, it is also typically used to include/exclude nodes and maintaining the Z-Wave network. Portable controllers are typically battery powered.

3.1.1.2 Installation Controller

The Installation Controller is essentially a Portable Controller node, which incorporates extra functionality that can be used to implement professional installer tools which need extended

network diagnostics. Like the Portable Controller, Installation Controller is a typically also battery powered.

3.1.1.3 Static Controller

The Static Controller is required to remain in a fixed position in the network, meaning that it should not be physically moved when it has been included in the network. Moreover it is required that the Static Controller is always in "listening mode" and it must therefore be mains powered.

The "always listening" advantage of the Static Controller allows other nodes to transmit frames to it whenever needed, both for uploading purposes as well as for consulting purposes.

The Static Controller has two important network features used for more advanced installations. Both controllers are described more thoroughly in the installation example chapters (4, 5):

Static Update Controller (SUC):

When a Static Controller is configured as a SUC the primary controller automatic send network updates to the SUC e.g. when a new node is included to the network. The node will therefore automatically appear in the SUC's topology map. Other controllers in the network should individually request the SUC for network updates. If no SUC is present the Primary Controller is responsible of updating all controllers in the network, which will typically be a manual process for the end-user. The SUC is capable of creating a new Primary Controller in case the original Primary Controller is lost or malfunctioning. There can only be one SUC in each individual network.

SUC ID Server (SIS):

When a SUC is also configured as a node ID server (SIS) it enables all other controllers to include/exclude nodes. The SIS automatically becomes the Primary Controller in the network when enabled. There can only be one SIS in each individual network. To avoid inconsistency are all node ID allocations maintained by the SIS.

3.1.1.4 Bridge Controller

The Bridge Controller is essentially a Static Controller node, which has the additional capability of representing devices from other network types like X10 or TCP/IP as virtual nodes in a Z-Wave network. This enables control of Z-Wave nodes from e.g. an X10 controller or vice versa.

3.1.2 Slave Nodes

The slave nodes are devices that do not contain routing tables. The so-called Routing Slave nodes and Enhanced Routing Slaves nodes however can contain a number of pre-configured routes (assigned to them by a controller).

Any slave node can act as repeater for frames going to other nodes. The only requirement for being able to act as repeater is that the node is in listening state. This requires that the node is permanently powered, and in order to save on battery consumption, this means that only mains-powered nodes will act as repeaters in most practical installations.

Battery operated slaves that do not listen continually are disregarded by controllers when they calculate routes.

There are three types of slave nodes.

3.1.2.1 Slave

The Slave node type is able to receive frames and reply if necessary. The slave node cannot host pre-configured routes to other nodes. The slave node is typically used for devices that only require input (and report status if polled) and do not generate frames unsolicited. An example of a device using this type could be a power outlet.

3.1.2.2 Routing Slave

The Routing Slave can host a number of routes for reaching other slaves or controllers. Such routes are called "Return Routes"¹. Routing Slaves can use these routes to communicate with either controllers or other slave nodes. The Routing Slave can either be A/C powered or battery powered. If the Routing Slave is A/C powered it is used as a repeater in the Z-Wave network, otherwise it will be disregarded when routes are calculated. The Routing Slave functionality is used for devices that need to report unsolicited status or alarms.

A special case of a battery powered routing slave is the Frequently Listening Routing Slave (FLiRS). This is a normal routing slave configured to listen for a wakeup beam in every wake-up interval. This enables other nodes to wakeup the FLiRS and sends a message to it.

An example of a routing slave node could be a thermostat or a Passive Infra Red (PIR) movement sensor. A wall switch might also be a routing slave and could then be used to control small lighting scenes, or to establish a kind of "virtual" 3-way switching. One usage for a FLiRS could be as the chime node in a wireless doorbell system.

3.1.2.3 Enhanced Slave

The Enhanced Slave has the same basic functionality as a routing slave node, but more software components are available because of more features on the hardware. Enhanced slave nodes have software support for External EEPROM and an RTC². An example of a device using this type of Slave nodes could be a Thermostat.

3.1.2.4 Zensor Net Routing Slave

The Zensor Net routing slave node is basically a routing slave node configured as FLiRS with the additional functionalities:

- Zensor Net binding
- Zensor Net flooding

The Zensor Net is an alternative network to the classic Z-Wave network having its own binding method and a mechanism to flood messages to the entire Zensor Net.

An example of a Zensor Net routing slave node could be a smoke detector.

¹ "Return Route" is a controller-centric term that was originally referring to a route going back to the controller. Seen from the routing slave, "Controller Assigned Route" might be a better term. However, "Return Route" is the established term in all Z-Wave documentation.

² Applies to the Z-Wave 100 series only. Later families feature an internal timer for wake-up control

3.2 Home ID

The Z-Wave protocol uses a unique identifier called the Home ID to separate networks from each other. A 32 bits unique identifier is pre programmed in all controller nodes at manufacturing. This unique 32 bits identifier is automatically used as Home ID during the installation of the Z-Wave network. If more than one controller is used in the network it is the 32 bits unique identifier of the first controller node used that governs the Home ID. Additional controller nodes will be assigned that same Home ID when included into the network. This is an automatic process that leaves the initial controller as the Primary Controller and the other controller(s) as Secondary Controller(s). In case a SIS is present in the network will it be allocated the Primary Controller role leaving the remaining controllers as Inclusion Controllers.

All slave nodes in the network will initially have a Home ID that is set to zero. In order to communicate in the network the Primary Controller need to assign them with its Home ID. It is only a Primary Controller or an Inclusion Controller that can assign Home ID's to a node.

3.3 Node ID

Node ID's are used to address individual nodes in a network. A Node ID is an 8 bits value and it is assigned to slave and controller nodes by a Primary Controller or an Inclusion Controller. The Node ID assigned to a device is only unique within a network defined by the unique Home ID. The application must not assume a default Node ID allocation when a network is created because the Node ID allocation algorithm depends on a number of factors.

See Figure 1 for a graphical representation of the Home ID and Node ID of four different nodes before and after installation. The original Home ID (0x00002222) is preserved when the Portable Controller gets the secondary controller role but not used as long it is a part of the network with Home ID 0x00001111.

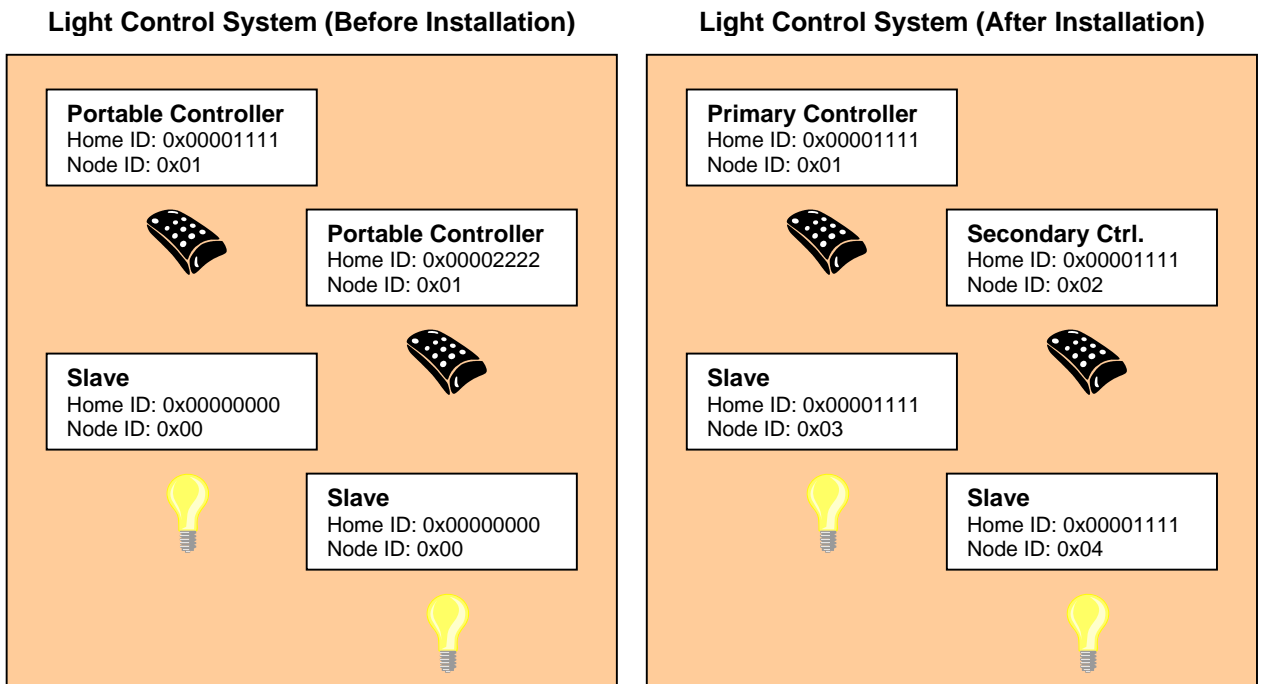

Figure 1. Assigning Home ID and Node ID

See Figure 2 for an illustration of how two adjoining networks will have different Home ID's because different controllers, with each their own unique Home ID's, were used to do the installation.

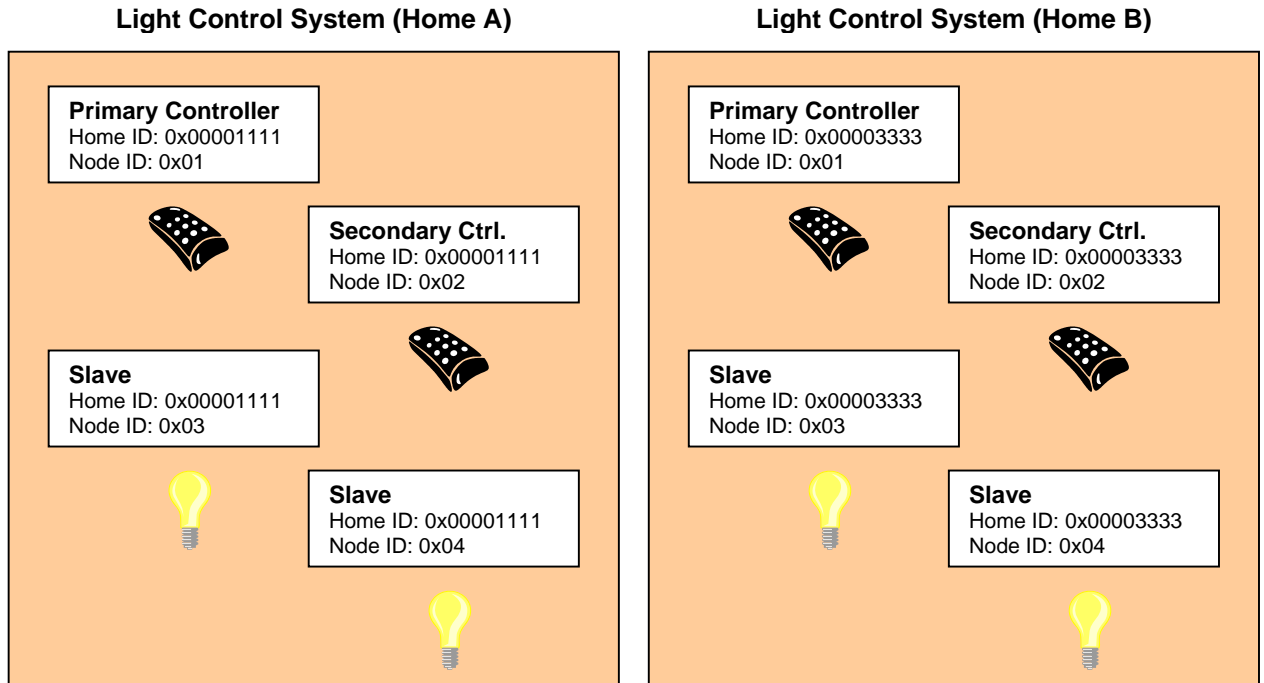

Figure 2. Unique Home ID for two adjacent homes

3.4 Routing

All controllers contains a routing table, which enables the controller to calculate routes in the Z-Wave network. Slave nodes will not have the ability to initiate transmission of routed frames, unless the controller has provided one or more controller assigned routes to the Routing Slave or Enhanced Routing Slave.

The forwarding mechanism for routed frames changed significantly from version 4.2x. Before that version, every frame transmission was acknowledged before the frame was forwarded to the next node in the path.

Version 4.2x makes use of the fact that the frame forwarded to the next node in the path is just as easy to hear from the originator as an acknowledgement frame would be. This trick is nicknamed "Silent Ack". By using silent ack, a lot of airtime is freed up and protocol latency is reduced.

Before version 4.2x: Full acknowledgement

The figure below shows an example of the frame flow when a frame is sent from a controller, repeated through a slave, to a second slave.

1. The controller sends a frame for slave 2 routed via slave 1
2. Slave 1 confirms the reception of the frame by sending out an ack.
3. Slave 1 repeats the frame.
4. Slave 2 confirms the reception of the frame by sending out an ack.
5. Slave 2 sends out a routed ack for end-to-end confirmation
6. Slave 1 confirms the reception of the frame by sending out an ack.
7. Slave 1 repeats the frame.
8. The controller confirms the reception of the frame by sending out an ack.

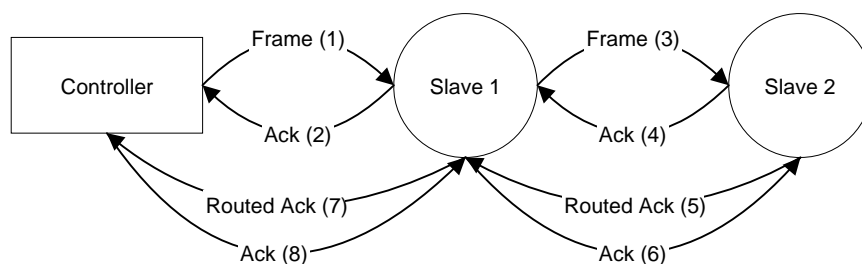

Figure 3. Routed frame flow

From version 4.2x: Silent acknowledgement

The figure below shows an example of the frame flow when a frame is sent from a controller, repeated through a slave, to a second slave.

1. The controller sends a frame for slave 2 routed via slave 1
2. Slave 1 repeats the frame.
The controller receives the frame and interprets this as an acknowledgement
3. Slave 2 sends out a routed ack for end-to-end confirmation
Slave 1 receives the frame and interprets this as an acknowledgement
4. Slave 1 repeats the frame.
Slave 2 receives the frame and interprets this as an acknowledgement
5. The controller confirms the reception of the frame by sending out an ack frame

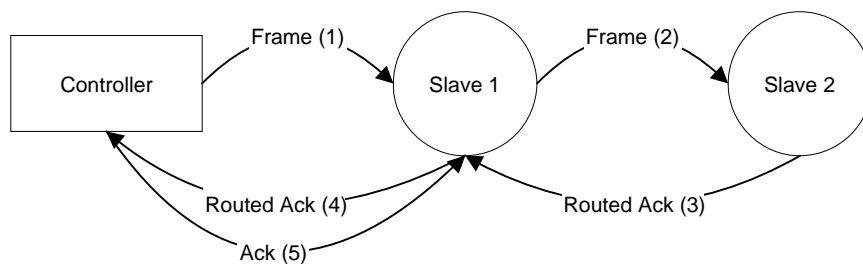

Figure 4. Routed frame flow w. silent ack

3.5 Initiators

The Z-Wave system is relying on the ability to include, exclude and operate nodes in the network, as described below. This requires that each device has a number of "Initiators". In the rest of this document an initiator does not necessarily mean a physical button. An Initiator can either be a physical button, a special activation of a button (e.g. activating a button for 2 seconds), a combination of buttons (e.g. activating two buttons simultaneously) or an item in a menu system.

3.5.1 Slave Initiators

The slave nodes only need one Initiator since all the intelligence is placed in the controller nodes. The slave initiator will be used for inclusion/exclusion, association/disassociation and operation depending on whether the initiators on the controller are activated or not. If additional features need to be supported, additional initiators may be required.

3.5.2 Controller Initiators

The controller nodes need at least the following initiators:

Include Initiator:

The include initiator is used when Primary and Inclusion Controllers include nodes in the network. When both the include initiator on the Primary/Inclusion Controller and a slave initiator have been activated simultaneously, the new node will be included to the network if the node was not included previously. Include initiator is activated on a Primary Controller or Inclusion Controller and on a controller that is un-initialized, this will result in the new controller is included to.

Exclude Initiator:

The exclude initiator is used by Primary Controllers to exclude nodes from the network. When the exclude initiator and a slave initiator are activated simultaneously, it will result in the slave being excluded from the network (and reset to Home ID zero). Even if the slave was not part of the network it will still be reset by this action.

Associate Initiator:

The associate initiator is used to associate nodes when both initiators on two nodes have been activated, the two nodes will be associated. This has the effect that when activating the operate initiator, all devices associated with this node is being operated.

Operate Initiator:

The operate initiator is used for controlling the functionality of the associated devices (e.g. a portable controller turning light on/off).

Controller Assigned Route Initiator:

The controller assigned route initiator is only needed in systems where the Primary Controller is required to generate controller assigned routes for Routing Slaves. The initiator is used to associate a Routing Slave with Static Controllers and other slaves.

Static Route Initiator:

The static route initiator is used when creating associations between slaves and static controllers out of direct reach. Using a portable controller, a two-step process is used to create an association. Refer to Figure 19, page 28, for details.

If additional features need to be supported, additional initiators may be required.

3.6 Node Information Frame

When the Include Initiator in a node is activated it will issue a node information frame. This frame is part of the Z-Wave protocol, and specifies the capabilities of the node. These capabilities announced include the node type, whether the node is able to repeat frames, and other protocol relevant issues. The node information frame also contains the Home ID and the Node ID.

It is possible for the application to ask for the Node Information Frame from all nodes in the network and hence enabling any node to acquire information regarding any other nodes features in the network at any given time.

4 Z-WAVE NETWORK FEATURES

This chapter contains information about functionalities in a Z-Wave Network.

4.1 Include/exclude Process

All nodes are required to take part in the include/exclude process. Only the Primary Controller and Inclusion Controllers in the network are able to include and exclude nodes. This strategy is chosen to ensure that the network stays consistent with respect to the Node ID's allocated.

From the Installer viewpoint all Z-Wave nodes (regardless of their node type) will use the same installation process.

4.1.1 Include Nodes

When a node is to be included in the network, the Primary Controller or Inclusion Controller will grant the request if there is Node ID's available. The network can consist of maximum 232 nodes.

4.1.1.1 Include slaves

The Include process is initiated by activating both the include initiator on the controller and the slave initiator. This causes the slave node to send out its node information frame. When the node information frame is received from an un-initialized node the controller will assign Home ID and Node ID to the slave. If a slave has already been assigned a Home ID and Node ID, it will not accept the inclusion. The Node will have to be excluded (or reset) before the node can be included again.

4.1.1.2 Include controllers

The include process is initiated by activating the include initiator on the Primary Controller or Inclusion Controller and the include initiator on the new controller that should be included into the network. The Primary Controller or Inclusion Controller will assign Home ID and Node ID to the new controller, which will then automatically become a Secondary or Inclusion Controller.

As part of the inclusion of additional controllers into the network, a replication of the routing tables and optionally other information will automatically take place. This ensures that the new controller have the newest information available. At later stages, when the Primary Controller has been updated with new nodes (or nodes have been deleted), a new replication can be initiated by activating the include initiators on both controllers as desired above. This network information updating can also be done automatically using the Static Update Controller functionality.

4.1.2 Exclude Nodes

The exclusion of Slave nodes happens when the exclude initiator on the Primary Controller and the slave initiator are activated. When nodes are excluded it will result in the node being reset and the topology information in the Primary Controller or Inclusion Controller being updated to reflect the change. This information is then passed on to the SUC if one is present.

When a slave node is reset, it will assume Home ID zero again. When a controller is reset, it will assume the Home ID it was originally programmed with during the manufacturing process.

The exclusion of a Controller happens when the exclude initiator both on the Primary and the Secondary Controllers are activated.

4.2 Association of nodes

When two nodes have been assigned to the network it is possible to associate these with each other. The following describes the different possibilities for associating nodes.

Convention: "A is associated with B" means that A is under the control of B.
For instance, A could be an outlet dimmer module and B could be a remote control.

4.2.1 Associating a Slave with a Controller

A slave node is associated with a controller by activating both the associate initiator on the controller to make it go into receive mode and the slave initiator on the slave to make it transmit its node information frame. The controller will receive the node information from the slave node and add the slave node to its internal associated nodes list maintained by the application layer.

Once a slave has been included to the network (see above) then it is possible to create associations with any controller. This functionality can typically be supported by a GUI wherefrom the node can be selected in a list.

Example: The slave is an outlet dimmer module and the controller is a remote control

4.2.2 Associating a (Routing) Slave with a Routing Slave

A (Routing) Slave is associated with a Routing Slave by using a Controller. The association of the nodes takes place by first activating the controller assigned route initiator on the Controller and the initiator on the destination Node (node that should be controlled). Secondly the controller assigned route initiator on the Controller and the initiator on the source node (node that should be controlling the association) are activated simultaneously. The Controller will then generate one or more routes and transmit these to the source node. This functionality can typically be supported by a GUI wherefrom the source and destination can be selected in a list and finally push out routes to the source via RF.

*Example: The slave is an outlet switch module and the routing slave is a movement sensor.
The controller used for association might be a portable controller.*

4.2.3 Associating a Static Controller with a Routing Slave

A Static Controller is associated with a Routing Slave by use of a Controller. The association of the nodes takes place by first activating the controller assigned route initiator on the Controller and the associate initiator on the destination Static Controller (node that should be controlled or informed about events). Secondly the controller assigned route initiator on the Controller and the initiator on the source node (Routing Slave node that should be controlling the association sending the event information) are activated. The Controller will then generate one or more routes and send them to the source node.

Example: The static controller is a wireless wall switch and the routing slave is a wall mounted scene controller. The controller used for association might be a portable controller.

Note: The static controller could set up this association by itself if it is somehow possible to communicate to it who the source node is (it is assumed that they are not within direct range in which case the situation would be similar to the "Associate a Slave with a Controller" example above). By using a controller for this job, the same procedure can be followed whether a routing slave is to control a slave, a routing slave or a static controller. Even more important, this procedure makes it possible for an end-user to set up his wall mounted scene controller without having to bother with whether this product is based on the controller or the routing slave libraries.

5 ZENSOR NET BASICS

In a classic Z-Wave network, the receiving node must be always listening. In order to support communication to battery-operated receiving nodes, a fundamentally different philosophy must be applied.

A Zensor Net is a network of battery-operated nodes that are able to operate for months or even years on the same battery, yet they are still able to communicate internally or via some master node.

5.1 The Zensor Net node

Certain applications (e.g. networked smoke alarms) have a hard requirement for robust, autonomous operation. During network configuration, it may be acceptable to have some centralistic approach, but operation must be 100% mesh oriented. Any subset of nodes breaking down must not cause the remaining nodes to loose contact to each other. For this purpose, Zensor Net nodes are able to forward broadcasted frames under certain conditions. This is covered in section 6.3.

In order to achieve a long battery life, Zensor Net nodes must be sleeping most of the time; only waking up for very short periods listening for traffic before they go back to sleep. The challenge in a Zensor Net is to get in contact with a node that only listens for a very short time now and then.

5.2 The Beam

The solution for reaching sleeping nodes is to introduce a “Beam”; a long preamble saying: “I have something for you, please hold the line”. The real frame then follows just after the beam.

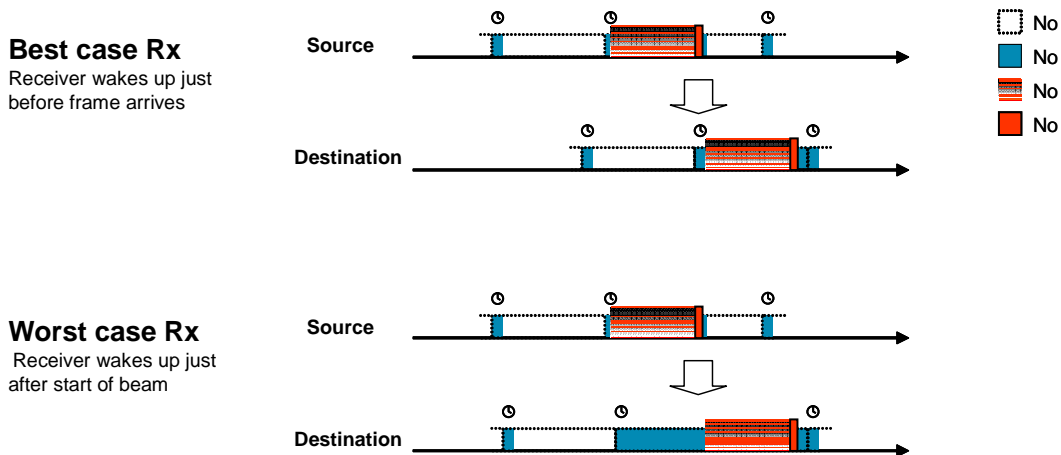

Figure 5. Reception timing when sending beams

In average, a listening node will detect the beam halfway through the beam.

There are multiple purposes of the beam:

1. It makes sure that a battery node detects that data is ready for it when the node actually wakes up.
By making the beam (slightly longer than) the length of the wake-up interval, the node will always wake up somewhere inside the beam.

2. The wake-up time is completely asynchronous and the precision of the wake-up timer is so limited that after 1 minute, the wake-up time may have drifted almost one second away from the nominal wake-up time.
Thus, a management system trying to read sensors will have no knowledge of the next expected wake-up time of a node that is read out at a rate lower than once per minute – which is the case for most battery sensor systems.
3. Without the beam, one could send out a high number of copies of the same frame from the application layer until an acknowledgement is received.
This strategy has two problems:
First, the listening node would have to be awake for a longer duration to detect the frame.
Second, there would be small pauses between the frames forcing the listening node to be awake for an even longer duration and even worse, there would be a risk that other nodes could send a frame in just that critical period where the listening node was awake and listening.

In Z-Wave v5.0, there is support for wake-up intervals of 250msec and 1000msec.

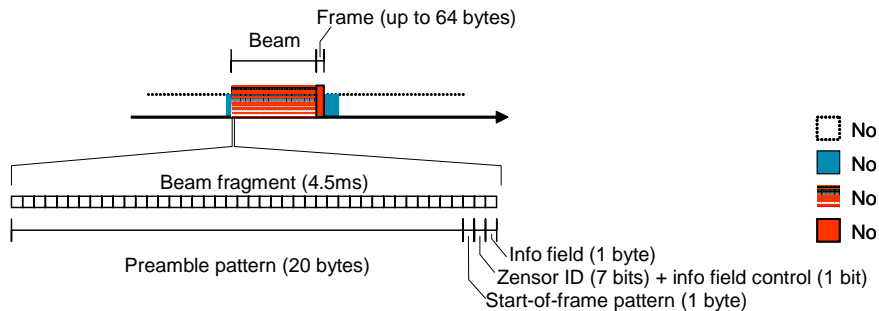

Figure 6. Structure of the beam

As mentioned above, one of the purposes of the beam is to block the air, ensuring that no other nodes disturb this attempt to reach a Zensor node. Blocking the air inevitably affects latency, command response times and ultimately end-user experience. Everybody having tried satellite telephony or bad graphical user interfaces knows that a half second delay from action to response is confusing and highly unsatisfactory. It is a known fact inside the telecom industry that the limit is somewhere around 300ms.

The 250msec wake-up interval stays below the 300msec limit. Actually, it is the absolute worst case delay caused by the beam that is 250msec. In average, it is 125msec, which hardly will be noticed at all by normal users turning a lamp on or off. Applications benefiting from the 250msec wake-up interval are battery-operated nodes such as wireless doorbell systems and wireless motion alarms, where low latency is critical.

The 1000msec wake-up interval is well beyond the 300msec limit and is not intended for use in Z-Wave environments during normal operation. The only application addressed by the 1000msec interval is a system of networked smoke alarms with a requirement for very long battery lifetime and moderate response times. The philosophy is that an emergency situation like a fire in the building is an extreme situation where longer response times are not an issue. The important part is that all alarms get started.

Zensor Net functionality is implemented as a backwards compatible extension to the classic Z-Wave protocol. Power information (battery / AC) and beam speed are taken into account when creating routes so that battery-operated nodes are not used as repeaters (existing Z-Wave feature) and so that a battery-operated node sending a frame takes into account the mode of the receiving node, as well as any repeaters used to reach the destination.

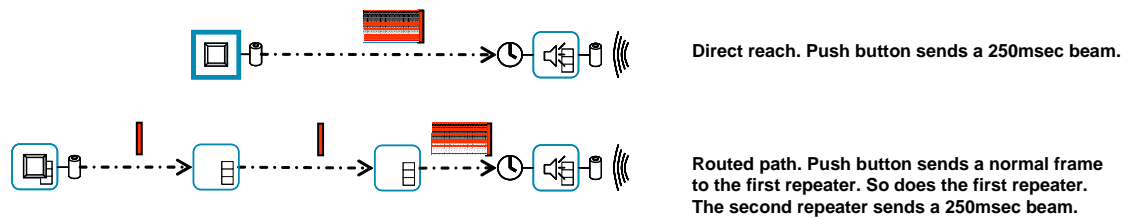

Figure 7. Battery-to-battery communication; direct reach and routed

Many topologies may be envisioned for sensor networks. Many of them focus heavily on battery lifetime and the ability to form ad-hoc networks. Some sensor networks have a large geographical coverage, causing some nodes to be out of direct reach from the management system controlling the sensors. In such environments, the principle outlined in Figure 7 may be used to create a mesh of many long-living sensor nodes and a few strategically located repeater nodes with large batteries, which takes all the burden of sending out beams.

Popularly speaking, you may be running 100 sensors with frequent communication on 3 batteries. In this way, sending a frame (e.g. responding to a data request) only requires the same power as waking up three times.

6 ZENSOR NET FEATURES

6.1 Applications

A range of applications may utilize the Zensor functionality.

Application	Communication mode	Latency requirement	Battery requirement	Z-Wave co-existence
Doorbell	Singlecast; classic Z-Wave @ 250msec wake-up	Very low latency	Moderate lifetime 2800mAh/year	Required
Smoke alarm	Multicast flooding @ 1000msec wake-up	Low latency	Long lifetime 700mAh/year	Some impact accepted

6.1.1 Doorbell

The doorbell application uses two battery-operated nodes; a doorbell push button and a chime. Figure 7 (first part) outlines such a system. The doorbell push button only wakes up when the button is pressed. The battery lifetime of the doorbell push button is very long.

In order to detect the button being pressed, the chime must wake up frequently, e.g. every 250msec. Therefore the chime is using significantly more power than the doorbell pushbutton.

In most cases, no traffic is detected and the node can return to sleep again after 4.5msec. When the button is pressed, the doorbell pushbutton node must send out a 250msec beam followed by a frame to ensure that the chime does receive the frame.

A special case of the doorbell application is outlined in the second part of Figure 7. Here, the pushbutton cannot reach the chime directly, but sends a routed frame which eventually ends up being beamed to the chime.

Setup of the system is entirely classic Z-Wave: The chime node is included with the doorbell pushbutton node.

Average current for a chime node is 320 μ A. On a year basis this equals 2800mAh, i.e. the capacity of normal AA cells; assuming a very low rate of chime activations.

6.1.2 Smoke alarm

The smoke alarm application is an extreme solution to an extreme situation. Up to 16 nodes must be able to reach each other at typically 10 seconds given whatever topology with no structured network configuration upfront.

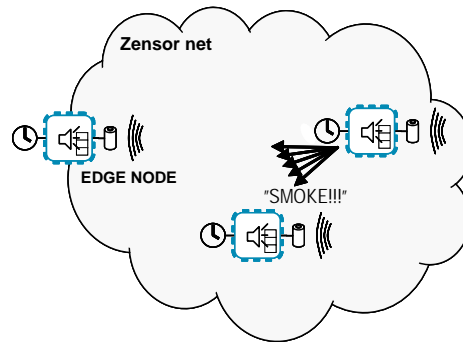

Figure 8. A flooded Zensor Net

The network configuration is limited to taking one, randomly chosen, smoke alarm and “binding” up to 15 other smoke alarms to that alarm. The binding process provides all alarm devices with the same, unique Zensor Net home ID.

The alarm devices can now be spread over a large area without any risk of breaking any pre-planned routed paths.

If a fire breaks out, the first smoke alarm to discover the fire starts sounding its audible alarm and at the same time, it sends out a 1000msec beam followed by a special “Zensor Net flooding frame” to the broadcast Zensor Net node ID 0xFF. The broadcast node ID makes all other smoke alarms within direct reach receive the transmission. The special flooding frame makes all receiving nodes forward the frame; also using the broadcast node ID. Broadcast loops are killed by having every smoke alarm only forward one copy of a given frame.

If many nodes received the broadcasted frame, many nodes will now want to forward a copy of the frame. A delicate arbitration mechanism ensures that the nodes spread out the transmissions in time, thus avoiding (or limiting) collisions.

Extensive simulations indicate that all nodes are reached and that the required time for activating all alarms is achieved in 99% of the cases. Up to 16 beams of 1000msec each jams the air effectively, but in a case of emergency, users may prefer that all alarms get started as fast as possible.

Note that a users command to turn on the light will not be dropped. Worst case, it will be delayed up to 1000msec, but it will end up reaching the lamp, thus allowing the user to get out of a smoke filled house.

As mentioned earlier, alarm nodes are interconnected using “Binding”. A high-end option exists, though. On top of a bind-configured Zensor Net, it is possible to include all Zensor Net nodes with a controller using classic Z-Wave inclusion. This enables a management system to make periodical checks of the availability and battery status of the nodes, while the nodes are still able to trigger each other completely independent of the central management system; a handy feature in case of power failure.

Average current of a smoke alarm is 80µA. On a year basis this equals 700mAh, i.e. less than the capacity of normal AAA cells (800mAh) and bit more than a 9V battery (650mAh); assuming no management communication.

In a managed system requesting status on a periodic basis, power consumption will be higher. One reading per hour, i.e. one message processing per 3600 wake-ups will only add marginally to the power consumption. An even more economical approach could be to program an interval in which the node by itself reports its presence to an always-on node; only contacting the node when initializing the management system or re-programming report intervals.

Checking for a beam takes 4.5ms radio listening. 3600 wake-ups equals 16.2 radio listening seconds. Thus, sending a 1sec beam once per hour would add 6% power consumption. Using always-on repeaters saves the Zensor beaming and makes status communication virtually costless.

6.2 Binding

The process of binding is a special feature tightly coupled to mesh applications such as smoke alarms. Binding provides Zensor Net nodes with a unique Zensor Net home ID and Zensor Net node ID. The Zensor Net home ID is used to restrict flooding within a specific Zensor Net. Flooding is explained in section 6.3.

Binding of Zensor Net nodes is performed by choosing one random node as the master. This master node has a role resembling that of a controller node in a classic Z-Wave network. All other Zensor Net nodes are bound to the master node, one at a time (The user should tag the master somehow in order to identify it again later). Binding may be performed by carrying the master around the house, binding nodes one at a time in their final locations or on the dining room table, binding all nodes in one chunk and mounting them afterwards. No routing tables are used, so the nodes may be moved around or exchanged without any implications for the operation of the remaining Zensor Net.

Binding is not a substitute for classic Z-Wave inclusion. Binding enables flooding in a restricted Zensor subnet and it enables the use of specially formatted flooding frames not compatible with classic Z-Wave, but required for controlling flooding.

6.3 Flooding

Zensor Net flooding is a special feature tightly coupled to mesh applications such as smoke alarms. Flooding ensures that all nodes can be reached at any time. A node running out of battery or being moved does not become a critical missing link for the distribution of a smoke alarm frame.

Flooding broadcast frames is not for free. Every node receiving a frame sends out a new broadcast frame. With no countermeasures, this behavior would lead to air congestion, collisions and infinite loops. Infinite loops are avoided in Zensor Nets by monitoring incoming broadcast frames. All Zensor Net frames carry a unique token, the "Flooding Frame ID". If a frame requests flooding, the node first checks if the Flooding Frame ID has been detected recently. The frame is only flooded if the Flooding Frame ID has not been met recently.

Trajectories of frames forwarded by Zensor Net flooding have some resemblance to the topology created by the Spanning Tree Protocol used to prevent infinite loops in Ethernet.

As mentioned above, infinite loops are only one of the challenges. Collisions are another threat. Zensor Net flooding uses a significantly different strategy for sending frames than classic Z-Wave. A Zensor Net with flooding is an environment with concurrent transmissions in different parts of the network and a high potential for collisions.

The strategy defined for Zensor Net traffic management is as follows:

- Zensor Nets with few nodes should have low latency for activation of all nodes.
- Zensor Nets with many nodes should relax the load; spreading out traffic in time in order to lower the amount of undetected collisions.
- Zensor Nets should leave room for other Z-Wave traffic. The latency is increased thanks to the one second beams but bandwidth must be available for control commands between the beams.

The implementation of Zensor Net collision avoidance and protocol back-off takes into account the number of nodes traversed before the actual transmission. The more hops, the bigger or more complex network. If the network has a high number of nodes, the risk of collisions is also bigger. Therefore, a large number of hops lead to a bigger window of time slots to choose between; the rationale being that if

too many frames collide, there is a risk that some nodes do not receive a valid frame at all. On the other hand, there is no need to delay frames too much if there are a low number of nodes in the network.

7 BASIC INSTALLATION EXAMPLE

This chapter contains some examples of how to install elements of a Z-Wave system in a sequential order. It also describes how nodes are associated.

7.1 Initial Setup

The most basic setup is one controller node and one slave node, as depicted in Figure 9.

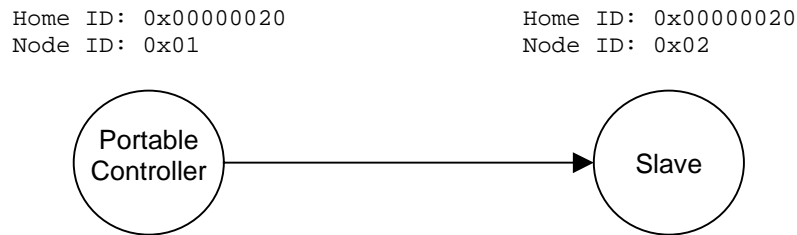

Figure 9. Including a Slave node.

Initially both the controller and the slave node are reset. The controller will have a predefined Home ID = 0x00000020) and a Node ID = 0x01. The slave have a predefined Home ID = 0x00000000 and Node ID = 0x00. Being the first controller in the system and therefore determining the Home ID, the controller defaults to become the Primary Controller and takes node ID = 0x01.

When the include initiator on the controller and the slave Initiator is activated simultaneously, the include procedure is initiated. The controller assigns the Home ID = 0x00000020 and the Node ID = 0x02 to the slave node. The slave is now part of the Z-Wave network, but no specific association has been made between the two nodes (the inclusion and the association process can be done as one interlinked action from the end-user's perspective).

7.2 Associating Nodes

The two nodes in Figure 10 are included in the same Z-Wave network, but have not yet been associated.

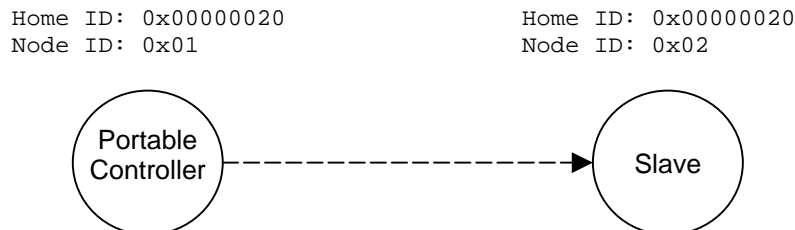

Figure 10. Associating a Slave Node with a Controller.

If the two nodes should be associated, this can happen by activating the associate initiator on the controller and the slave initiator simultaneously. This will cause the controller to listen for a node to associate. When the slave sends a node info frame (specified by the Z-Wave protocol and prompted by activating the slave initiator), the controller will include the slave in the associated slaves list.

Every time the operate initiator on the controller is activated, the controller will send a message to the slave node, which will cause the slave node to perform the specified action.

7.3 Adding Slave Nodes

New slave nodes can be included in the Z-Wave network as the network is gradually expanded. In Figure 11, the example is extended to include another slave node. The inclusion happens the exact same way as for the first slave node. The second slave node will be assigned the Home ID = 0x00000020 and the Node ID = 0x03. The second slave node can also be associated with the controller by activating the associate initiator on the controller and the slave initiator simultaneously. The result is depicted in Figure 11.

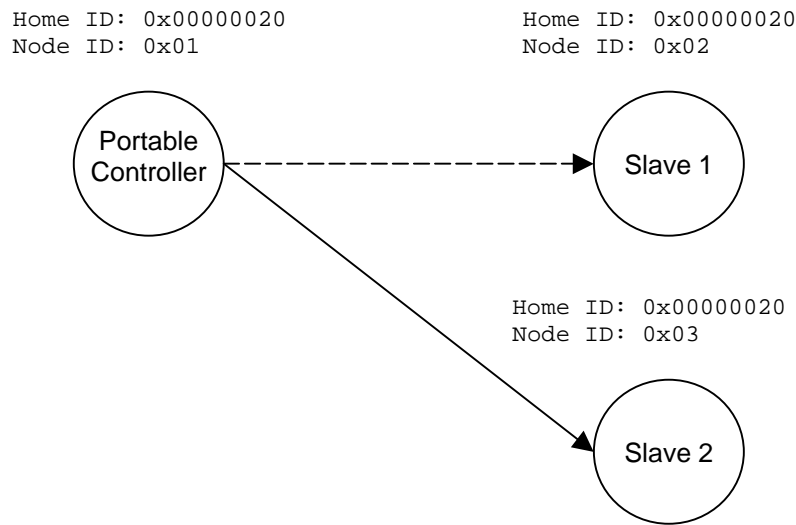

Figure 11. Including Slave node 2.

The second slave node can also be associated with the controller by activating the associate initiator on the controller and the slave initiator simultaneously as shown on Figure 12.

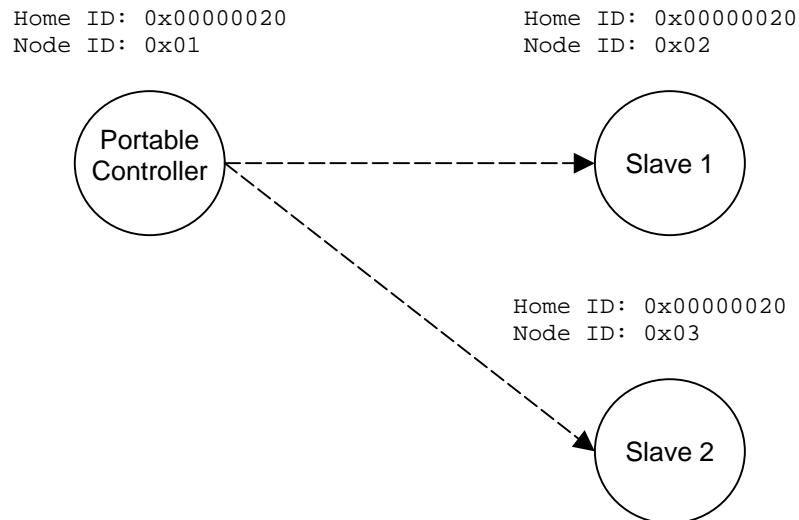

Figure 12. Associating Slave Node 2 with the Controller.

7.4 Adding Controllers

The Z-Wave network can also be extended to include multiple controllers. Figure 13 shows a system with 2 controllers.

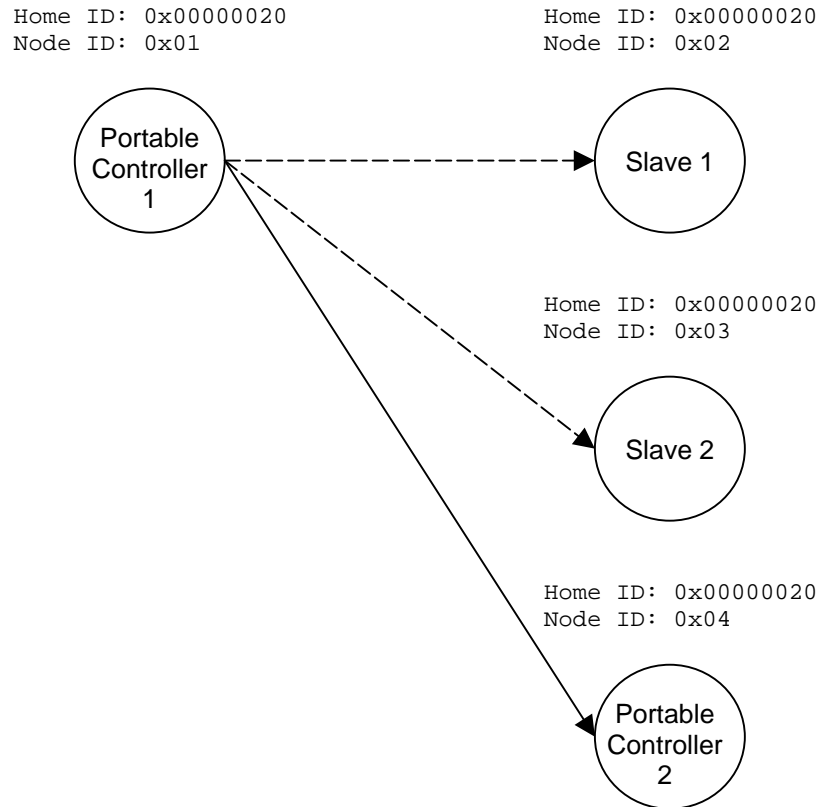

Figure 13. Including a second Controller.

The second controller to be added comes with another unique default Home ID, for example 0x00000030 and Node ID = 0x01. When the Include initiator is activated on both controllers, the include process is initiated. The first controller, which acts as Primary Controller for the Z-Wave network, will assign the Home ID = 0x00000020 and the Node ID = 0x04 to the second controller, which now assumes the position as a Secondary Controller.

Following the exchange of network identifiers a replication will take place. During the replication process, all routing information will be transferred from the Primary Controller to the Secondary Controller. The Secondary Controller is now able to perform all the same functionalities as the Primary Controller except from including/excluding nodes in the Z-Wave network.

Additional slave nodes can be assigned to the Z-Wave network by the Primary Controller and associated with either controller 1, controller 2 or both. In Figure 14 below two slave nodes has been included with the Primary Controller and associated with controller 2.

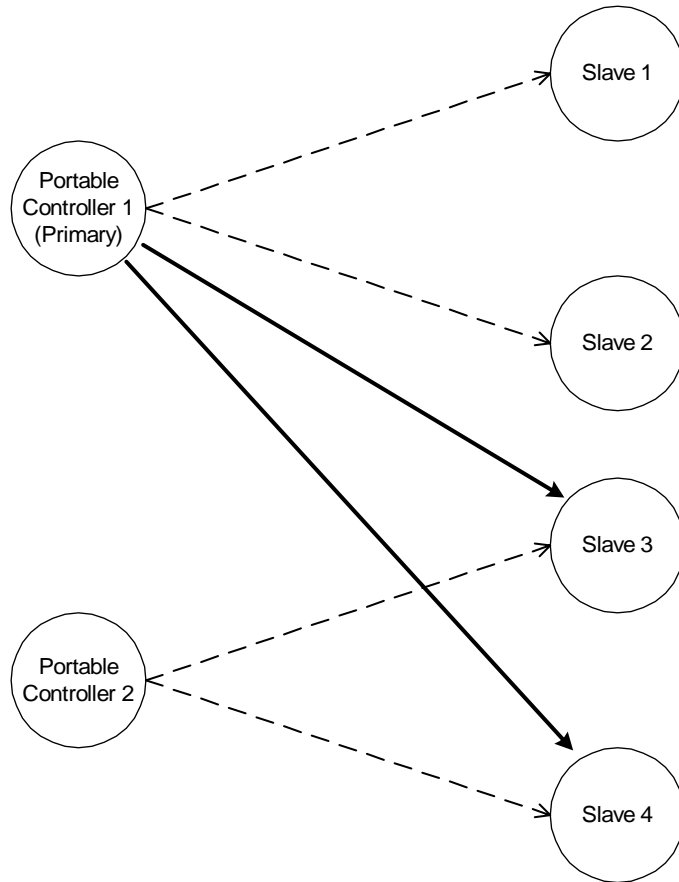

Figure 14. Including and associating additional Slave nodes.

The Portable Controller 2 can be associated with slave 3 and slave 4. The routing table of Portable Controller 2 will not be updated before Portable Controller 1 performs a controller replication.

7.5 Removing Slaves

A slave node can be removed from the Z-Wave network by activating the exclude initiator on the Primary Controller and the slave initiator. This action will cause the controller to send Home ID = 0x00000000 and Node ID = 0x00 to the slave, thereby resetting the slave. The controller will also remove the routing information from the routing table.

7.6 Removing Secondary Controllers

A Secondary Controller can be removed by activating the exclusion initiator on both the Primary Controller and the Secondary Controller.

7.7 Recover from Controller Node Error

If a controller fails, recovery depends on whether it is a Primary Controller or a Secondary Controller. If it is a Secondary Controller it can just be removed, a new can be included and the routing information can be replicated.

If the failed controller is the Primary Controller the situation is different. Basically the entire network can be reset and then reconfigured with a new controller. This controller will then become the new Primary Controller. The unique 32 bits identifier of the new Primary Controller will now be the new Home ID for the entire Z-Wave network.

A more advanced method is to use the Network management features of the Z-Wave Network.

If a Static Controller is configured as a Static Update Controller (SUC), it will keep an updated version of the routing table. All controllers in the system may request updates from the SUC. The primary controller is required to send updates to the SUC when new nodes have been included or old nodes have been reset. If the Primary Controller malfunctions, a secondary controller can be requested to be primary by making replication from the SUC.

A SUC basically implements a mirror service for the primary controller, allowing the user to reconstruct all topology settings and inclusion data in a new primary controller; should the primary controller break down.

Note that associations and other application-level data is not stored in the SUC. The SUC only holds protocol-level data. Thus, the SUC increases the network robustness but it is not a general backup service.

8 STATIC CONTROLLER AND ROUTING SLAVE EXAMPLE

This chapter extends the previous example to also include Static Controllers and Routing Slaves. The starting point for this example is a network with a Portable Controller and two slave nodes.

8.1 Including Routing Slaves

The first step in this scenario is to include a Routing Slave, see Figure 15.

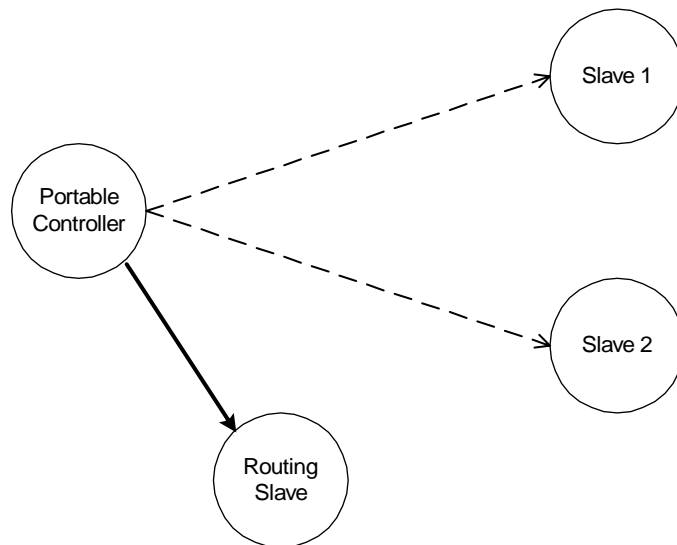

Figure 15. Including a Routing Slave.

The Routing Slave is included in the network in the exact same way as any other slave node. When the include initiator on the controller and the initiator on the Routing Slave are activated, the controller will assign Home ID and Node ID to the Routing Slave.

The Routing Slave can now be associated with a controller or another slave. The controller is an important part of facilitating the association process although it is not part of the final association.

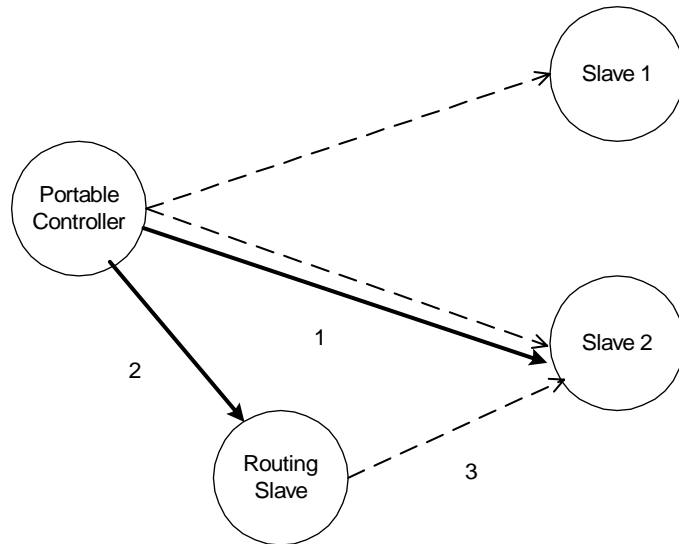

Figure 16. Associating a “Simple” Slave with a Routing Slave.

The controller needs an extra initiator compared to the previous example. This initiator is called a controller assigned route initiator. The controller assigned route initiator on the controller and the initiator on slave 2 (the device to be controlled) are activated. The procedure is repeated for the Routing Slave. Upon doing the second part of the association, the controller will calculate one or more routes between the Routing Slave and Slave 2. These routes will be sent to the Routing Slave, which will use the routes when communicating with Slave 2.

8.2 Including Static Controllers

This part of the example describes a situation where the network initially consists of one controller and three Routing Slaves. This network is depicted in Figure 17.

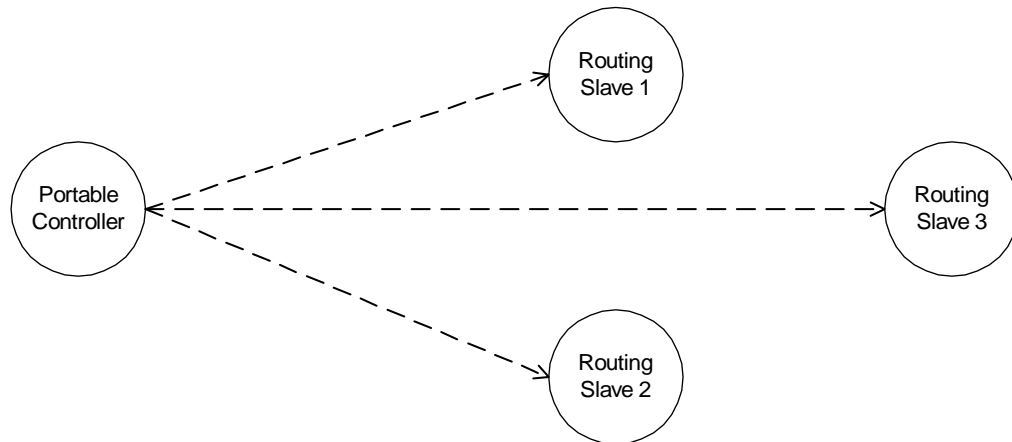

Figure 17. Controller with three associated Routing Slaves.

The following figure shows the previous example extended with a Static Controller. A Static Controller is included in the same way as a Portable Controller. The Static Controller will be assigned a Home ID and a Node ID, and the topology information is transferred. The main difference in the inclusion procedure is that the Static Controller automatically investigates which neighbours it is able to see during the include process. Figure 18 illustrates the network after the Static Controller has been included.

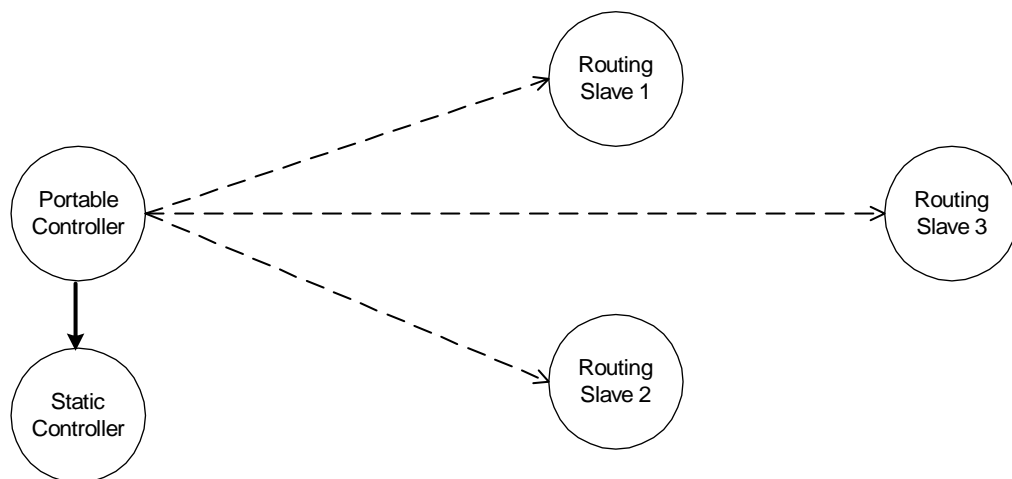

Figure 18. Including a Static Controller.

The Portable Controller now contains the full routing information, including the knowledge of which nodes that can be reached directly from the Static Controller.

In this scenario it is now possible to create an association that allows a Routing Slave to communicate with the Static Controller.

In the following example we want to associate the Static Controller with the Routing Slave 3. In the example it is assumed that the Static Controller can only reach Routing Slave 1 and Routing Slave 2

directly. Also for the Routing Slave 3 it is assumed that it is able to reach Routing Slave 1 and Routing Slave 2 directly, but not the Static Controller.

The Association is done as described in the previous example, by first moving the Portable Controller within range of the Static Controller, and then activating the static route initiator on the Portable Controller and the associate initiator on the Static Controller. Secondly the Portable Controller is moved closer to Routing Slave 3. When the associate initiator on the Portable Controller and the initiator on slave 3 have been activated, the Portable Controller will calculate routes from Routing Slave 3 to the Static Controller. In this example the Portable Controller will come up with two alternative routes. The first route is to reach the Static Controller through Routing Slave 1. The second route is to reach the Static Controller through Routing Slave 2.

Figure 19 shows the Z-Wave network after the Static Controller has been associated with Routing Slave 3.

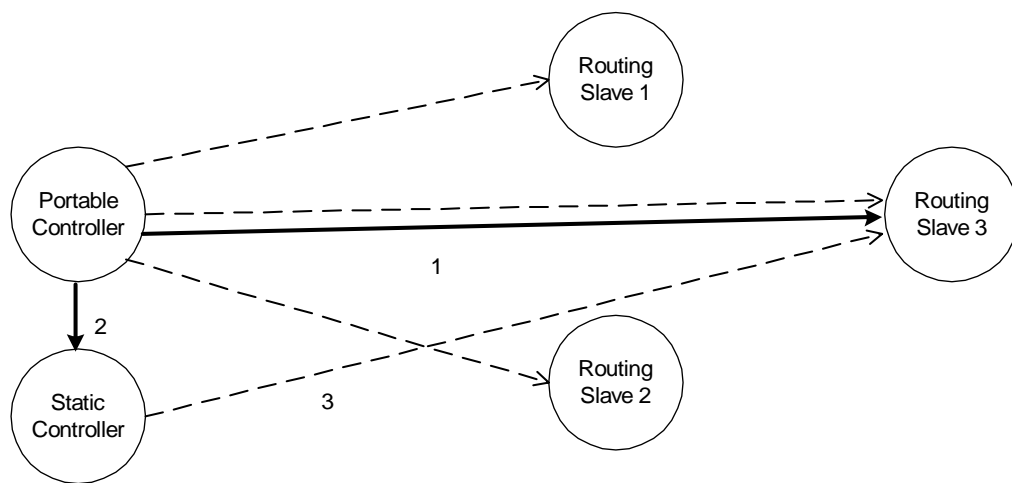

Figure 19. Associating a Static Controller with a Routing Slave.

9 STATIC UPDATE CONTROLLER (SUC) EXAMPLE

When a Static Controller is configured as a Static Update Controller (SUC) then it will automatically receive all changes in the network topology from the Primary Controller. Other nodes in the network can acquire this information.

Note that only one SUC can be present in each individual network.

9.1 Including a SUC to the network

The following step describes the process of including a SUC to the network:

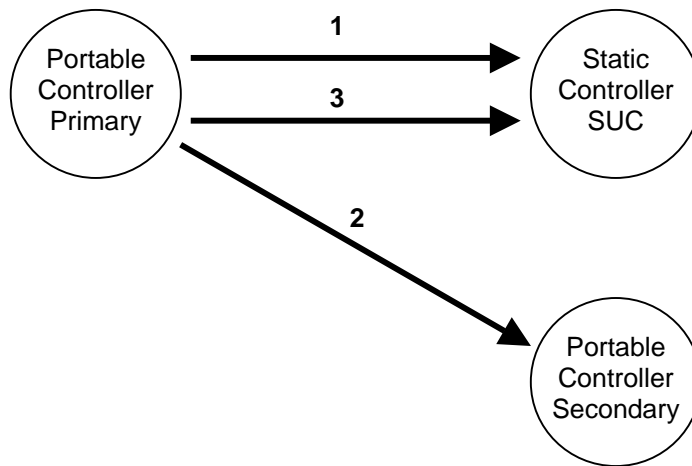

Figure 20. Including a SUC to the network.

- 1) Include the Static Controller as described in the previous chapter by replicating the information from the Primary Controller to the Static Controller. The Static Controller is now included to the network and is secondary. Afterwards will the application on the Primary Controller assign the Secondary Static Controller to become the SUC.
- 2) The Primary Controller includes an additional Portable Controller node to the network in same way as described in previous chapters.
- 3) The Primary Controller will automatically send the updated network topology for the included Secondary Portable Controller to the SUC. From now on every time a new node (controller or slave) is included to the network the SUC will get the updates automatically.

Association is done exactly as described in previous chapters.

It is recommended to include the SUC as the first node in the network because new nodes can then be advised about its presence when included.

Adding a SUC to an existing network will cause battery-operated nodes, such as portable controllers, to be unaware of the SUC. Such nodes will never be able to request topology updates from the SUC.

10 SUC ID SERVER (SIS) EXAMPLE

The SUC may be further configured with node ID server (SIS) functionality to enhance installation flexibility. The SIS enables other controllers to include/exclude nodes to/from the network. When SIS functionality is enabled the controller also takes the role as the Primary Controller because it has both latest network topology and allocated node IDs. All the other controllers are called Inclusion Controllers because they can include/exclude nodes to/from the network. Until the SIS is included to the network the installation process is as described in the previous installation chapters.

Note that only one SIS can be present in each individual network.

10.1 Including a SIS to the network

The following step describes the process of including a SIS to the network.

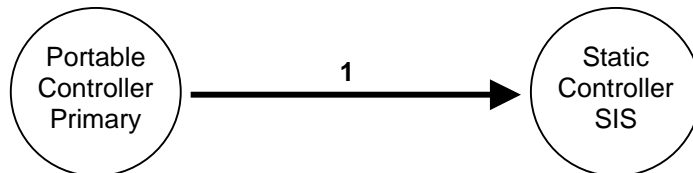

Figure 21. Including a SIS to the network.



Figure 22. After SIS is included to the network.

1. Include the Static Controller as described in the previous chapter by replicating the information from the Primary Controller to the Static Controller. The Static Controller is now included to the network and is secondary. Afterwards will the application on the Primary Controller assign the Secondary Static Controller to become the SIS. The SIS becomes the Primary Controller after inclusion and the old Primary Controller becomes an Inclusion Controller.

It is recommended to include the SIS as the first node in the network because new nodes can then be advised about its presence when included.

Adding a SIS to an existing network will cause battery-operated nodes, such as portable controllers, to be unaware of the SIS. Such nodes will never be able to request topology updates from the SIS.

10.2 Adding inclusion controllers to the network

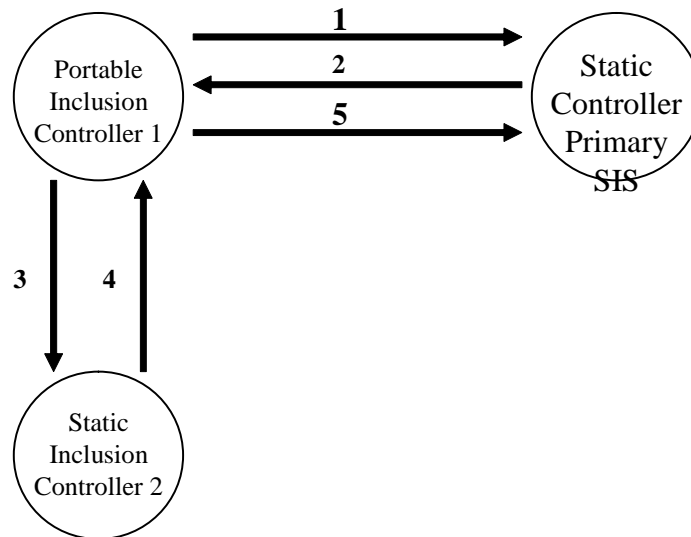

Figure 23. Including an Inclusion Controller to the network.

1. Inclusion Controller 1 requests an available node ID for the new Static Inclusion Controller 2 and the latest network topology from the SIS
2. The SIS provides a node ID and the latest network topology to the Inclusion Controller 1.
3. Inclusion Controller 1 now assigns the allocated node ID to Static Inclusion Controller 2. Based on the latest network topology the Static Inclusion Controller 2 check for neighbors within direct range. (Check for neighbors within direct range is not done in case the Inclusion Controller 2 is portable)
4. The Inclusion Controller 2 returns neighbor information to Inclusion Controller 1. In case Controller 2 is a static controller based on an old library without Inclusion Controller capability then it becomes a Secondary Static Controller.
5. The Inclusion Controller 1 updates the SIS with the latest network topology discovered during the inclusion of Inclusion Controller 2.

11 REFERENCES

- [1] Zensys, INS10247, Instruction, Z-Wave ZW0102/ZW0201/ZW0301 Application Programming Guide.