

Dimmer selection

Today you will find one or several lights that can be dimmed in almost every household. Among these are also dimmer solutions for low voltage halogen lamps (12 V) e.g. in rope systems or downlights.

Incandescent lamps, high and low voltage halogen lamps or motors e.g. for extractor fans - can be dimmed, i.e. their power consumption is reduced. They all require dimmers with different technical features.

Before installing, you must make sure that the dimmer is compatible with the load, and that loads with different input behaviour are not mixed behind a dimmer. This can cause problems, especially when extensions are made to the existing installation.

This is why Merten has labelled the dimmers and transformers in the catalogue, in the technical information and on the appliances themselves.

Labelling

Labelling:

Four simple letters "R", "L", "C", "M" or a combination of these and a symbol divide the dimmers into classes by marking their default loads:

R for ohmic loads (e.g. incandescent lamps)

L for predominantly inductive loads (e.g. conventional 50 Hz/60 Hz transformers for e.g. low voltage halogen lamps)

C for predominantly capacitive loads (e.g. MET, electronic transformers for incandescent halogen lamps or low voltage halogen lamps)

M for motors.

The dimming symbol indicates the brightness or speed control options.

If several letters apply to one dimmer, then only one of these can be used next to "R" for all connected loads. The labelling of the loads must correspond to the selected symbol. At present, a dimmer cannot operate "L" and "C" load types in one switching circuit simultaneously. Thereby incorrect combinations are avoided to a large extent, e.g. phase control dimmer instead of phase alignment dimmer.

- Check that at least one identical letter is marked on the dimmer and transformer. Then your combination of appliances is correct.
- Make sure that L and C loads are not combined behind a dimmer. Even a dimmer with several symbols cannot operate mixed L / C installations.

Example: The dimmer is a universal R,L,C type; R and L load types are already installed. The new load must then be R or L, but not C under any circumstances.

Load reduction

The connected loads mentioned are for single flush-mounted installations; this applies to all dimmers. The maximum connected load must not be reached if the dimmer cannot dissipate sufficient heat - e.g. when installed in cavity walls or in surface-mounted housing.

Reduction of connected loads for dimmers

| Cause \ Reduction in % | Dimmer installed in cavity or wooden walls* | Several dimmers installed in combination* | Several built-in dimmers installed next to each other on a DIN rail.* | Dimmer installed in 1- or 2-gang surface-mounted or console housing | Dimmer installed in 3-gang surface-mounted or console housing |
|------------------------|---|---|---|---|---|
| 25 % | ■ | ■ | ■ | | |
| 30 % | | | | ■ | |
| 50 % | | | | | ■ |

*If several factors occur at the same time, then reductions are added.

Example 1: Two dimmers are installed in multiple combination in a wooden wall: The load reduction **per** dimmer is then $25\% + 25\% = 50\%$.

Example 2: Three dimmers are installed in a 3-gang surface-mounted housing: The load reduction **for each** dimmer is 50%.

Reduction of the connected load for universal super dimmer insert, art. no. 577099

| Cause \ Reduction in % | Dimmer installed in cavity or wooden walls* | Several dimmers installed in combination* | Dimmer installed in surface-mounted housing* |
|------------------------|---|---|--|
| 10% | | | ■ |
| 15% | ■ | | |
| 20% | | ■ | |

*If several factors occur at the same time, then reductions are added.

Example 1: Two universal super dimmers are installed in multiple combination in a wooden wall: The load reduction **per** dimmer is then $15\% + 20\% = 35\%$.











Example 2: Three universal super dimmers are installed in a 3-gang surface-mounted housing: The load reduction **per** dimmer is then $10\% + 20\% = 30\%$.

DIMMER SYSTEMS AND TRANSFORMERS

Dimmer and load types

Table of available dimmer and load types

(The table is not exhaustive)

| Dimmer type: | Standard phase control dimmer | Low voltage phase control dimmer | Phase alignment dimmer | Universal dimmer | Speed controller |
|---|---|---|---|---|---|
| Load type: |  |  |  |  |  |
| Standard incandescent lamps  | Rs match ↓ OK , Combination possible! | Rs match ↓ OK , Combination possible! | Rs match ↓ OK , Combination possible! | Rs match ↓ OK , Combination possible! | No match ↓ Combination unsuitable! |
| High voltage halogen lamps  | Rs match ↓ OK , Combination possible! | Rs match ↓ OK , Combination possible! | Rs match ↓ OK , Combination possible! | Rs match ↓ OK , Combination possible! | No match ↓ Combination unsuitable! |
| LV halogen lamps with wound transformer  | No match ↓ Combination unsuitable! | Ls match ↓ OK , Combination possible! | No match ↓ Combination unsuitable! | Ls match ↓ OK , Combination possible! | No match ↓ Combination unsuitable! |
| LV halogen lamps with electronic transformer with cap. characteristics  | No match ↓ Combination unsuitable! | No match ↓ Combination unsuitable! | Cs match ↓ OK , Combination possible! | Cs match ↓ OK , Combination possible! | No match ↓ Combination unsuitable! |
| LV halogen lamps with electronic transformer with ind. characteristics  | No match ↓ Combination unsuitable! | Ls match ↓ OK , Combination possible! | No match ↓ Combination unsuitable! | Ls match ↓ OK , Combination possible! | No match ↓ Combination unsuitable! |
| Motors  | No match ↓ Combination unsuitable! | No match ↓ Combination unsuitable! | No match ↓ Combination unsuitable! | No match ↓ Combination unsuitable! | Ms match ↓ OK , Combination possible! |

Installation of super dimmers in existing installations

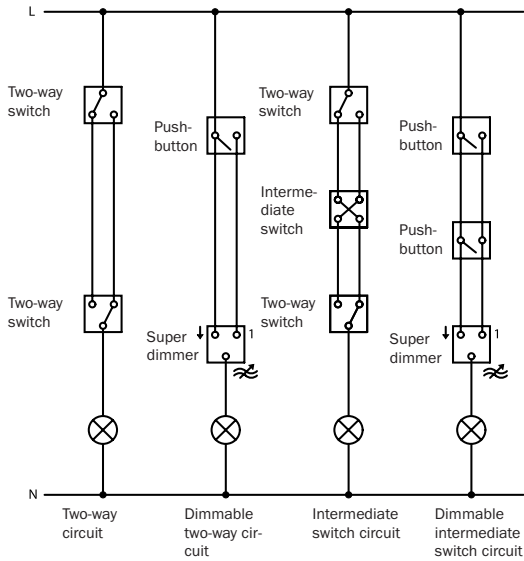

- The graphic shows how to convert a conventional two-way or intermediate switch circuit to a convenient, dimmable two-way or intermediate switch circuit in combination with Merten super dimmers.
- New systems should have conventional two-way or intermediate switch circuits wired, in order to maintain maximum subsequent flexibility.
- The push-buttons can be replaced by electronic extension units or TELE extension units (for IR remote control), art. no. 573999 or 573998, depending on the customer's requirements.
- Mixed operation is possible with electronic extension units and push-buttons.
- Switching ON/OFF and dimming UP/DOWN is possible from every operating unit.
- For memory ET super dimmer insert, art. no. 577899: Extension operation is only possible with mechanical push-buttons or the universal relay insert, art. no. 575897, with configured push-button function.

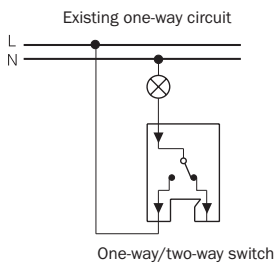

Replaced by

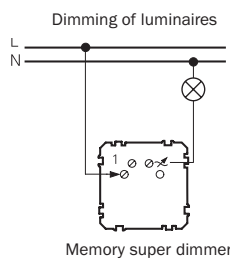

Dimming of luminaires

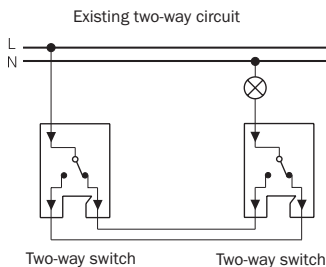

Replaced by

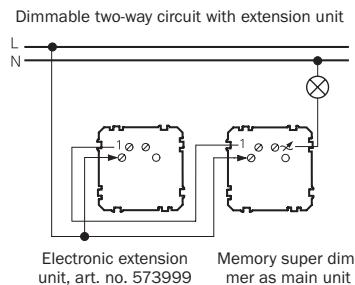
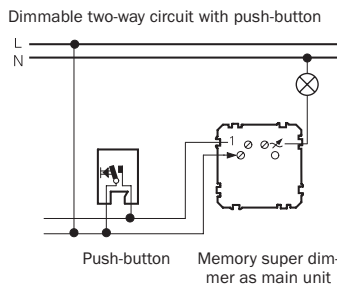

Dimmable two-way circuit with TELE extension unit

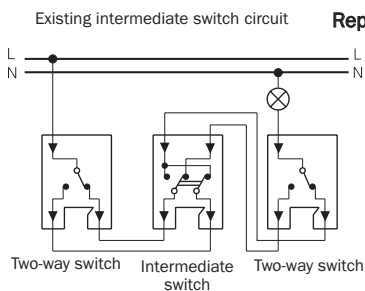
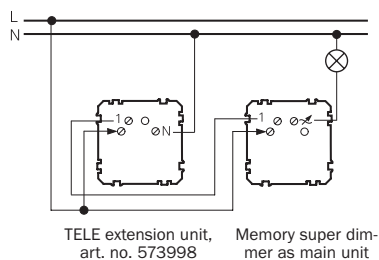

Replaced by

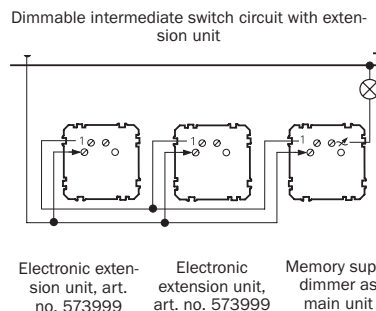
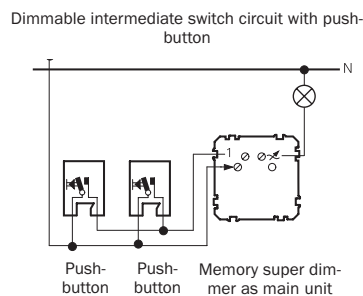

DIMMER SYSTEMS AND TRANSFORMERS

Phase control dimmer for ohmic loads

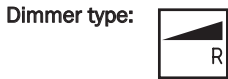

- Connections:
- ⋈ Connecting terminal for the load
 - 1 Connecting terminal for the control cable
 - Connecting terminal for the phase

Rotary dimmer for incandescent lamps in one-way circuit

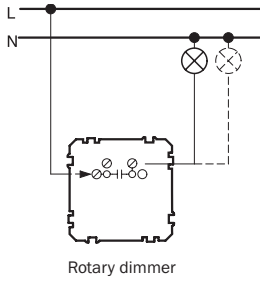

Rotary dimmer for incandescent lamps in two-way circuit

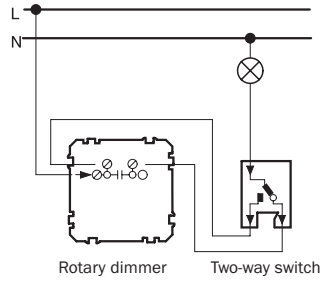

Rotary dimmer for incandescent lamps in one-way circuit with power booster

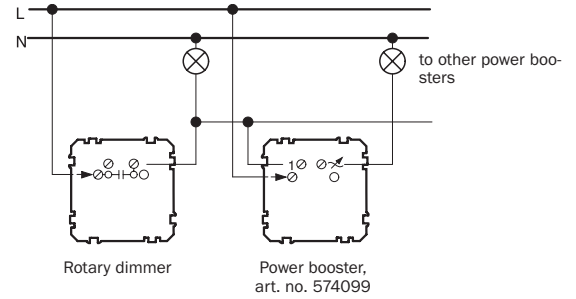

Rotary dimmer for incandescent lamps in two-way circuit with power booster

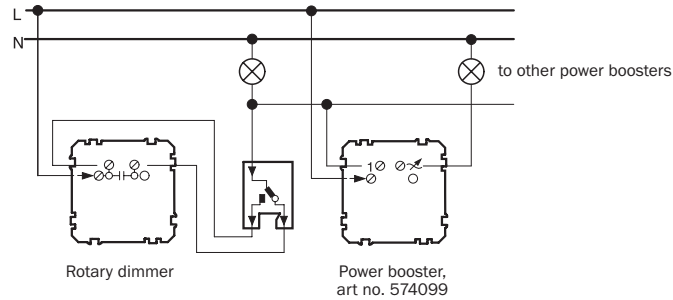

Memory super dimmer and TELE dimmer e.g. in existing two-way or intermediate switch circuits

Dimmable two-way circuit with push-button

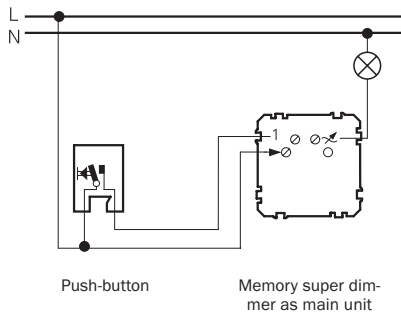

Dimmable two-way circuit with extension unit

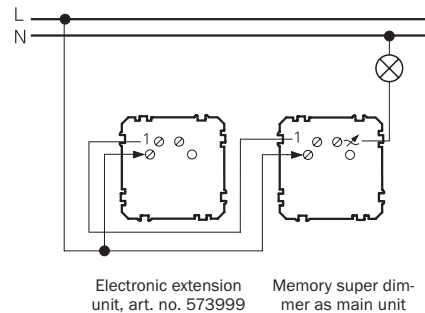

Dimmable two-way circuit with TELE extension unit

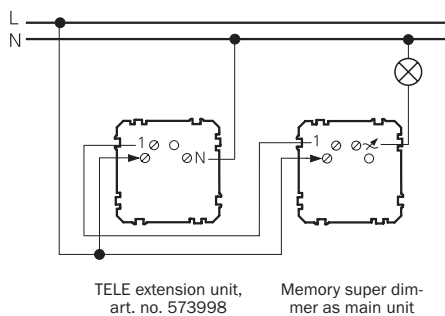

Memory super dimmer with power booster

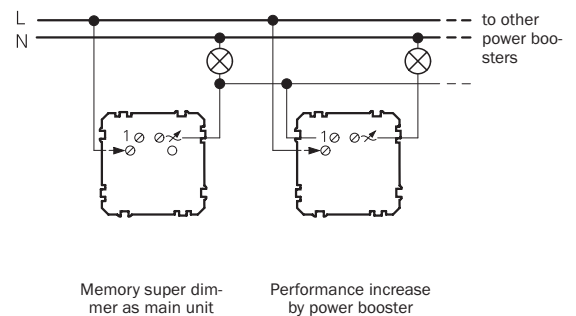

Phase control dimmer

for LV halogen lamps with conventional, wound transformers

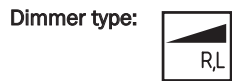

- Connections:
- ∞ Connecting terminal for the load
 - 1 Connecting terminal for the control cable
 - Connecting terminal for the phase

With the Merten dimmers 5725.., 5735.. and 5770.., you can control conventional, wound laminated core transformers for LV halogen lighting. Several transformers can be connected in parallel up to a maximum connected load of 500 VA. It must be ensured that it is always the transformer's power that applies, even if it is only partially loaded.

Mixed operation of transformers and ohmic loads can be carried out without any problems if you observe the output data. For technical reasons, a power extension for the operation of inductive loads is not possible. The use of conventional toroidal transformers can cause problems, if they have not been explicitly declared for dimming operation.

Halogen rotary dimmer e.g. in existing two-way circuits

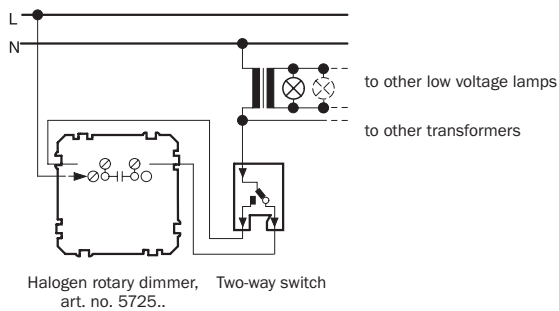

Halogen rotary dimmer as stand-alone device

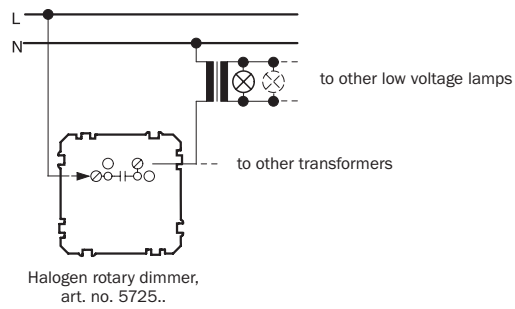

Halogen memory super dimmer as a stand-alone device

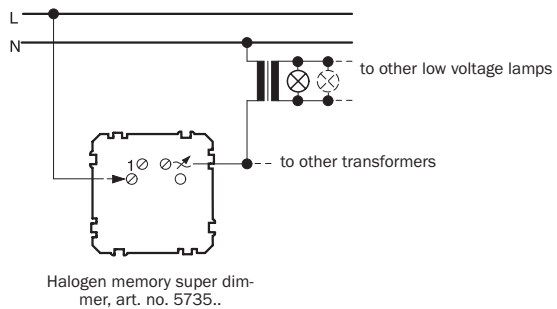

Extension operation with push-button and/or electronic extension units

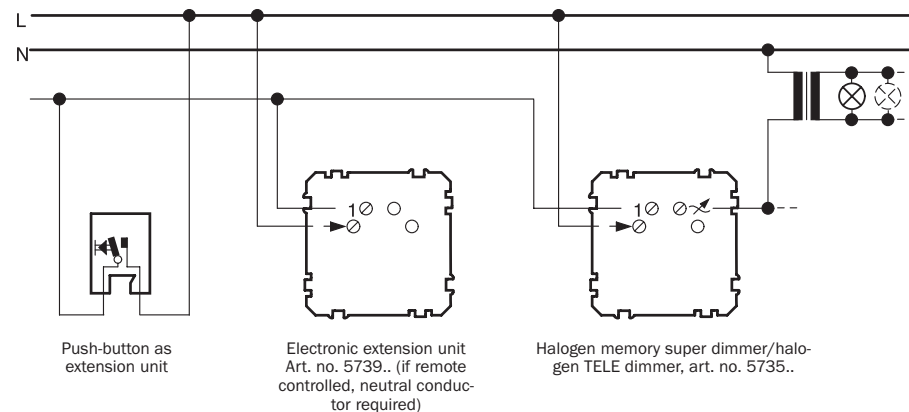

Phase alignment dimmer

for LV halogen lamps
with electronic transformers

Dimmer type:



- Connections:
- ⌘ Connecting terminal for the load
 - 1 Connecting terminal for the control cable
 - ➔ Connecting terminal for the phase

In contrast to conventional dimmers with phase control, ET dimmers no. 5771.., 5778.. and 5770.. follow the phase alignment principle. Only these dimmers can activate electronic transformers for low voltage halogen lamps. The maximum power that can be connected is 315 W for electronic transformers as well as incandescent lamps. It should be noted that it is always the maximum power for the transformer that is relevant. Conventional inductive, i.e. wound transformers must not be connected, as they can destroy the ET dimmer. Advantages of the ET dimmers: no humming, no short circuits (no change of fuse required), overload protection, soft start function to protect the lamps and switching memory function for art. no. 5778 ...

The MET B transformer 105 W, art. no. 577796, the MET B transformer 200 W, art. no. 577791, as well as several electronic transformers made by other manufacturers can be controlled by ET dimmers. Electronic transformers are smaller, lighter and safer than conventional wound transformers using the same power.

Normal AC 230 V incandescent lamps or AC 230 V halogen lamps can be connected, instead of MET B transformers. Extension unit operation of ET memory super dimmers is only possible with **mechanical push-buttons**.

With one or more ET power boosters, no. 577399, the connected load can be increased by 315 W each time.

ET memory super dimmer as a stand-alone device

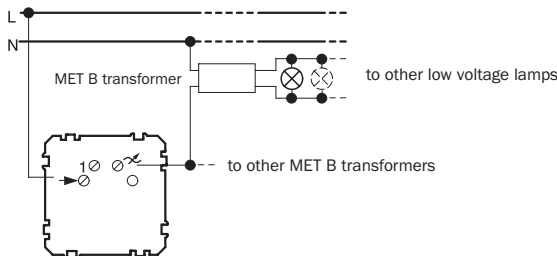

ET memory super dimmer, art. no. 5778... with sensor or TELE push-button cover

ET rotary dimmer as stand-alone device

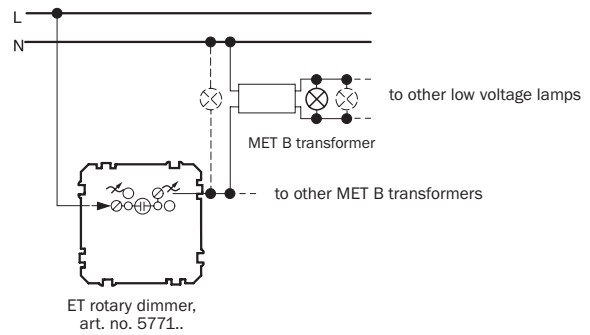

ET rotary dimmer, art. no. 5771..

Et rotary dimmer in existing two-way circuits

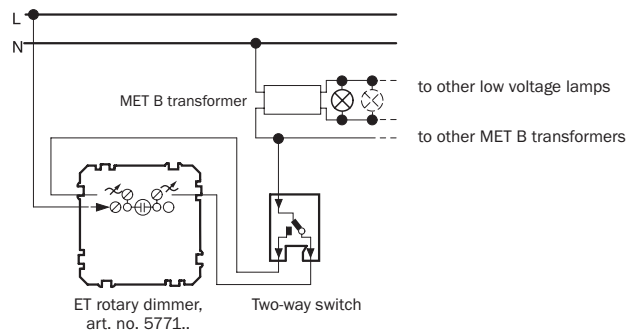

ET rotary dimmer, art. no. 5771..

ET memory super dimmer in extension unit operation with push-button and/or ET power boosters

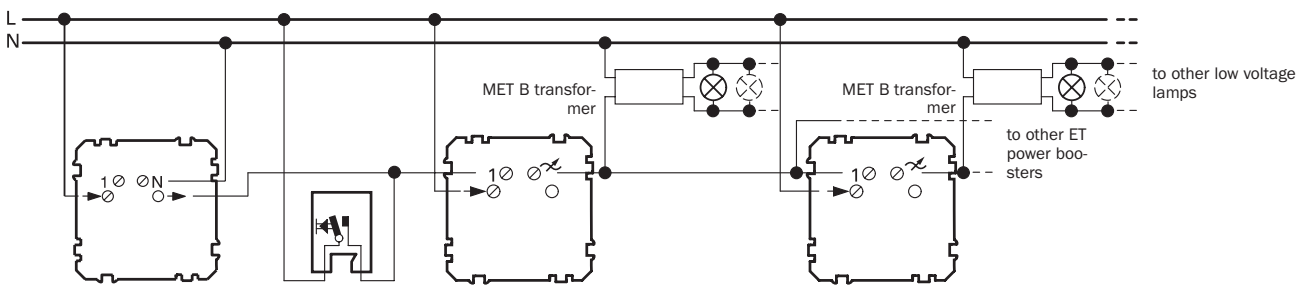

Universal relay insert, art. no. 575897, with push-button function with sensor or TELE sensor cover

Push-button

ET memory super dimmer, art. no. 5778... with sensor or TELE sensor cover

ET power booster, art. no. 577399 with blanking cover

Universal dimmer with phase control or phase alignment

for incandescent lamps, LV halogen lamps with wound transformers or with electronic transformers

Dimmer type:



- Connections:**
- ⌘ Connecting terminal for the load
 - 1 Connecting terminal for the control cable
 - Connecting terminal for the phase

With the Merten universal dimmer 577099, loads can be dimmed with the inductive component (e.g. conventional, wound laminated core transformers for LV halogen lighting) or with the capacitive component (e.g. LV halogen lighting with electronic transformer MET B). Mixed operation of transformers and ohmic loads (incandescent lamps) can be carried out without any problems if you observe the output data.

Caution!

The combination of a load with inductive behaviour and a load with capacitive behaviour can damage the dimmer and must be avoided. The universal dimmer 577099 detects the connected load type automatically and requires for this purpose a minimum load of 25 VA.

Loads can be connected up to a maximum connection load of 420 VA. When determining the performance of transformers, observe that it is always the power of the transformer that applies, even if it is not fully loaded.

The use of conventional toroidal transformers can possibly cause problems, if they have not been explicitly declared for dimming operation by the manufacturer.

Extension operation with push-button and/or electronic extension units

Ohmic load

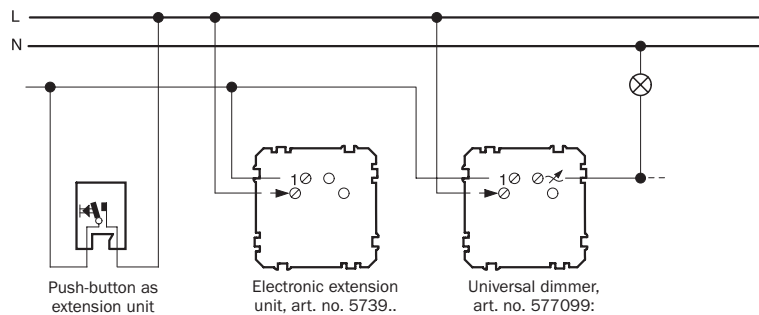

Inductive load

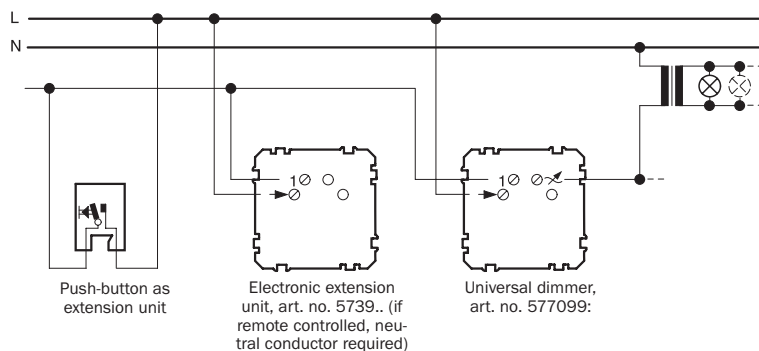

Capacitive load

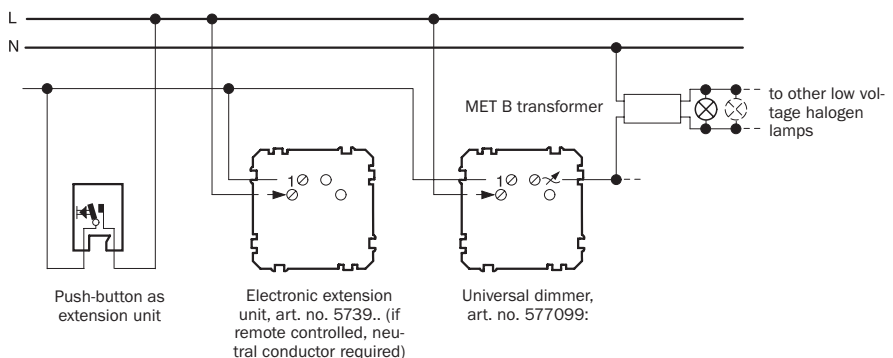

DIMMER SYSTEMS AND TRANSFORMERS

Appliances for controlling fluorescent lamps and motors

Electronic potentiometer insert combined with electronic ballasts and contactor

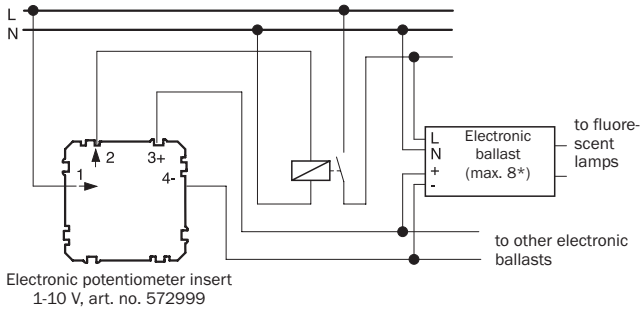

* 1 mA per electronic ballast
If electronic ballasts with a higher load are used, then correspondingly fewer electronic ballasts can be connected.

Electronic potentiometer insert combined with electronic ballasts

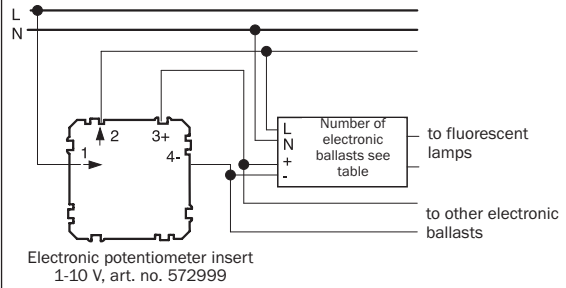

Max. load of switch contact (terminals 1 and 2)

| | Ø 26 mm | Ø 38 mm |
|-------------------------|---------|--------------|
| 12 fluorescent lamps at | 18 W | 20 W |
| 9 fluorescent lamps at | 36 W | 40 W (1.2 m) |
| 7 fluorescent lamps at | | 40 W (1.0 m) |
| 6 fluorescent lamps at | 58 W | 65 W |

Controlling motors and dimming other inductive loads





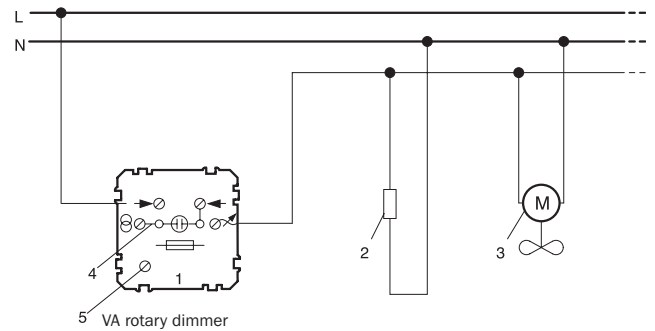



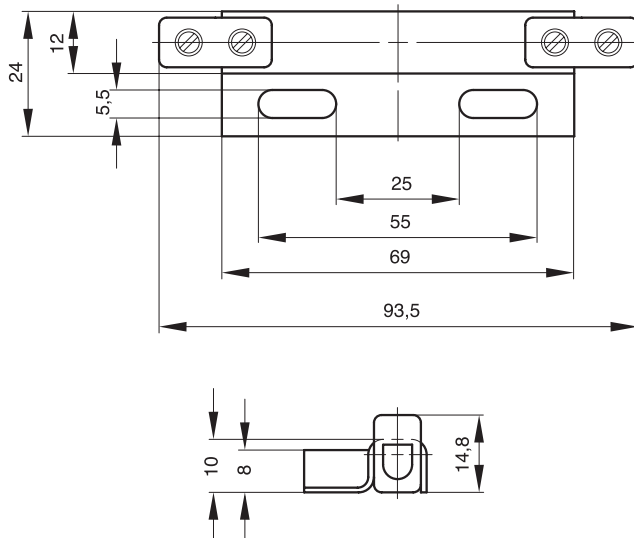













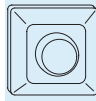



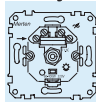





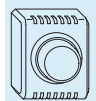



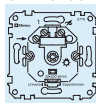

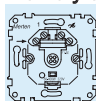



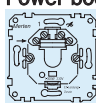

- 1 Rotary dimmer 600 VA, art. no. 573299
- 2 Base load
- 3 Motor, fan
- 4 Potentiometer

- The base load can be composed of at least 3 resistors of 6 W each (base load 542894 consists of 4 separate 6 W resistors).
- An incandescent lamp (min. 25 W) is also a base load. It must however never be removed from the circuit.
- The safe startup of the motor is set with potentiometer 5.



Base load, art. no. 542894, e.g. for rotary dimmers



| Lamp/dimmer matrix | | | | | | | | | | | |
|---|---|---------------|-----------|---|---|--|---|---|---|---|--|
| Dimmer/control units | Lamps | | |  |  |  |  |  |  |  | |
| | Type | Version | Art. no. |  |  |  |  | |  |  | |
| Rotary dimmer complete devices, flush-mounted | | | | | | | | | | | |
|  |  | 60 - 400 W | 572124/74 | ■ | ■ | | | | | | |
| |  | 60 - 400 W | 572424/74 | ■ | ■ | | | | | | |
| |  | 60 - 600 W | 572224/74 | ■ | 500 W | | | | | | |
| Rotary dimmer inserts, flush-mounted / Potentiometer insert 1-10 V | | | | | | | | | | | |
|  |  | 60 - 400 W | 572499 | ■ | ■ | | | | | | |
| |  | 60 - 600 W | 572299 | ■ | 500 W | | | | | | |
| |  | 75 - 1000 W | 572799 | ■ | 700 W | | | | | | |
| |  | 20 - 500 VA | 572599 | ■ | ■ | ■ | | | | | |
| |  | 20 - 315 W | 577199 | ■ | ■ | | ■ | | | | |
| |  | 25 - 600 VA | 573299 | ■ | 500 W | 500 VA | | | ■ | | |
| | | 1 - 10 V | 572999 | | | | | | ■ | ■ | |
| Rotary dimmer complete devices, surface-mounted | | | | | | | | | | | |
|  |  | 60 - 400 W | 573444/19 | ■ | ■ | | | | | | |
| |  | 60 - 400 W | 573417 | ■ | ■ | | | | | | |
| |  | 60 - 600 W | 571644/19 | ■ | 500 W | | | | | | |
| |  | 60 - 600 W | 571617 | ■ | 500 W | | | | | | |
| Universal super dimmer insert | | | | | | | | | | | |
|  |  | 25 - 420 VA | 577099 | ■ | ■ | ■ | ■ | | | | |
| Memory super dimmer inserts, flush-mounted | | | | | | | | | | | |
|  |  | 60 - 400 W | 573399 | ■ | ■ | | | | | | |
| |  | 60 - 600 W | 577299 | ■ | 500 W | | | | | | |
| |  | 20 - 500 VA | 573599 | ■ | ■ | ■ | | | | | |
| |  | 20 - 315 W | 577899 | ■ | ■ | | ■ | | | | |
| Power boosters, flush-mounted | | | | | | | | | | | |
|  |  | 25 - 600 W/VA | 574099 | ■ | 500 W | | | | ■ | | |
| |  | 20 - 315 W | 577399 | ■ | ■ | | ■ | | | | |
| Built-in rotary dimmer | | | | | | | | | | | |
|  |  | 60 - 500 W | 571829 | ■ | ■ | | | | | | |
| |  | 20 - 500 VA | 572529 | ■ | ■ | ■ | | | | | |
| |  | 20 - 280 W | 577129 | ■ | ■ | | ■ | | | | |
| Built-in memory super dimmer | | | | | | | | | | | |
|  |  | 20 - 500 VA | 573529 | ■ | ■ | ■ | | | | | |
| |  | 20 - 280 W | 577829 | ■ | ■ | | ■ | | | | |
| Built-in power booster | | | | | | | | | | | |
|  |  | 25 - 500 W/VA | 574029 | ■ | ■ | | | | ■ | | |
| MET S control unit 1-10 V | | | | | | | | | | | |
|  | | 1 - 10 V | 577794 | | | | | | ■ | ■ | |

MET B: For the right start

Electronic transformer, art. no. 577796 (105 W), art. no. 577791 (200 W)

Electronic transformers of the MET B system are integrated in LV lighting installations, if these installations are switched with conventional installation switches or if an output of up to 315 W is to be dimmed with phase alignment dimmers.

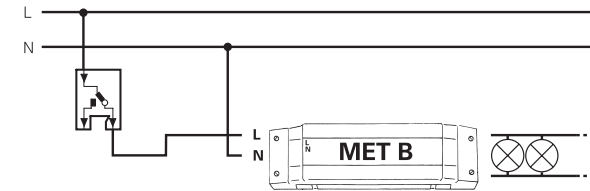

Two-way switch

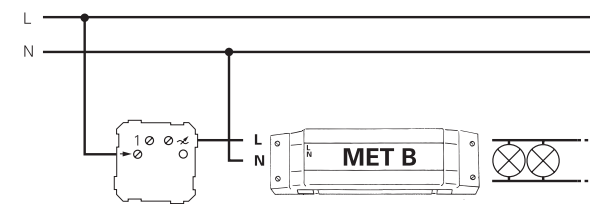

Memory ET super dimmer insert for capacitive load

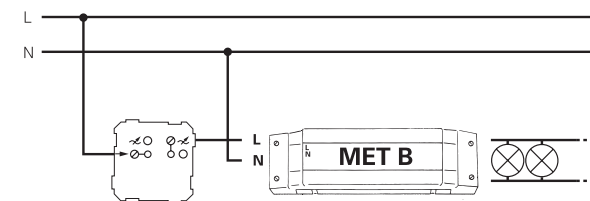

ET dimmer insert for capacitive load

MET D: All-purpose

Electronic transformer with integrated dimmer, art. no. 577798

The electronic transformers with integrated dimmer, as part of the MET D system, can be switched and dimmed with as many mechanical push-buttons as required (make contacts) and/or with maximum 10 electronic extension units, art. no.: 573999 (with sensor cover) or maximum 10 electronic TELE extension units, art. no.: 573999 (with TELE sensor cover).

Press the button briefly or touch the sensor cover to switch the transformer on or off. Hold the button down or actuate the operating unit and the transformer slowly dims the light up or down. The memory function, that can be switched off, saves the last selected brightness value, that is automatically activated when the appliance is switched back on. Activating and deactivating the memory function is achieved by briefly pressing or touching ten times within 8 seconds.

The electronic soft start function ensures that the appliance is switched on in a pleasant, "soft" manner, which also doubles the service life of the LV halogen lamps.

Electronic transformer for power extension, art. no. 577797

If MET D LV lighting installations with outputs exceeding 105 W up to maximum 1700 W are required (observe specifications of the local electricity board), then this transformer can be used for power extension purposes.

Signals are transmitted via a control cable between the electronic transformer with integrated dimmer and the electronic transformer for power extension. When up to 5 transformers are installed for power extension, then the control cable must be connected in the form of a star. Each of the 5 power extension transformers has a separate output for a new control cable, to which again max. 5 new power extension transformers can be connected (circuit diagram). There is a limit to this line arrangement of the transformers, determined by the connection conditions of the local electricity board, of max. 1700 W per phase. All appliances must be connected to the same phase. The maximum length of the individual control cables between the appliances must not exceed 20 m. Cross-over points between control cables and secondary cables must be avoided.

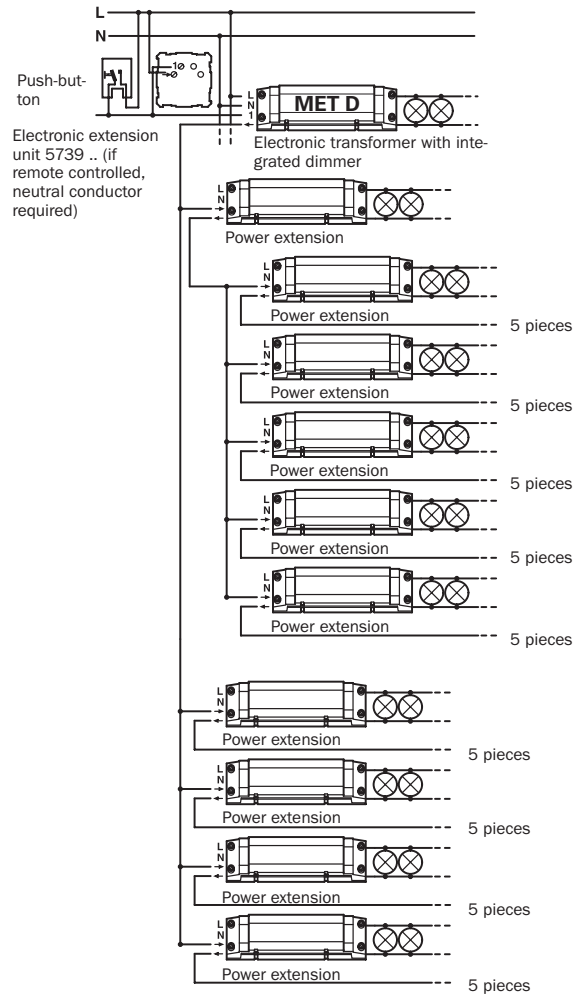

MET S: For great solutions

Electronic transformer with 1-10 V control input, art. no. 577795

Electronic transformers with 1-10 V control input are integrated in LV lighting installations, if a high output is to be dimmed from one operating unit (electronic potentiometer insert 1-10 V, art. no. 572999) or from several operating units (MET S control unit 1-10 V, art. no. 577794, EIB control units 1-10 V).

Up to 50 transformers with 1-10 V control input can be operated and controlled with an electronic potentiometer insert 1-10 V. At the same time, the mixed operation of up to 50 other appliances such as fluorescent lamps and electronic ballasts with 1-10 V control input is possible. With the MET S control unit, up to 100 transformers or appliances with 1-10 V control input can be connected. If, in doing so, the maximum load of 1700 W per phase is exceeded (observe specifications of the local power supplier), further appliances (max. 3 x 1700 W) can be distributed to the remaining phases.

There are no particular constraints on the 1-10 V control cable regarding its length or being arranged alongside other installation cables. If the total output of all of the transformers or electronic ballasts exceeds the allowed **switching capacity** of the electronic potentiometer insert (6 A) or of the MET S control unit (10 A) or if the total output is distributed among several phases, then a power relay is added to the circuit (circuit diagrams).

